

ANYRIDGE[®]

by MEGA'GEN





*Be confident,
you are using a
CLEAN IMPLANT!*



TRUSTED QUALITY Award 2017-2023
From the CLEAN IMPLANT FOUNDATION

MegaGen's mission is to manufacture the highest quality implants,
and this Trusted Quality Award is the confirmation of our commitment.
For more information about the Clean Implant
Foundation, please visit www.cleanimplant.com

Contents

➔ AnyRidge
010 - 083





➔ AnyRidge Kit
091 - 102

➔ R2GATE :
Digital Dentistry
104 - 126

AnyRidge

010		AnyRidge Characteristics & Advantages	030		Angled Abutment
019		AnyRidge Fixture	030		CCM Abutment
023		Cover Screw	036		Extra EZ Post Abutment (EZ Post Type) (Milling Type)
023		Healing Abutment	037		Cover Screw (Extra Type)
025		Impression Coping (Transfer Type) (Pick-up Type)	037		Extra Healing Abutment
026		Lab Analog	037		Lab Analog
026		Temporary Abutment	038		Impression Coping (Transfer Type) (Pick-up Type)
026		Fuse Abutment	038		Temporary Abutment (Titanium Extra Type)
028		EZ Post Abutment	040		Solid Abutment
029		GOLD Abutment	041		Snap Impression Coping
029		Zirconia Abutment	041		Comfort Cap
029		Milling Abutment	041		Lab Analog

041		Burn-out Cylinder	051		Lab Analog	065		Temporary Cylinder
043		Octa Abutment	051		Temporary Cylinder	065		EZ Post Cylinder
043		Healing Cap	051		CCM Cylinder	065		Healing Cap
043		Impression Coping (Transfer Type) (Pick-up Type)	052		Healing Cap	065		Impression Coping (Transfer Type)
044		Lab Analog	052		Try-in Abutment	065		Impression Coping (Pick-up Type)
044		Temporary Cylinder	053		Multi-unit Driver	065		Gold Cylinder
045		EZ Post Cylinder	053		Right Angle Driver	065		CCM Cylinder
045		Gold Cylinder	053		Hand Driver	065		Plastic Cylinder
046		CCM Cylinder	053		Removal Driver	067		Flat Abutment
046		Plastic Cylinder	055		Surgical Guide	067		Flat Cover Screw
050		Multi-unit Abutment (All-on-4) (N-Type)	064		Multi-unit Angled Abutment (All-on-4) (S-Type)	067		Flat Healing Abutment
051		Impression Coping (Pick-up Type)	065		Lab Analog	067		Flat Impression Coping (Transfer Type) (Pick-up Type)

Contents

➔ AnyRidge
010 - 083



➔ AnyRidge Kit
091 - 102

➔ R2GATE :
Digital Dentistry
104 - 126

AnyRidge

067		Flat Lab Analog	075		Meg-Ball Metal Housing Set
068		Flat Temporary Cylinder	075		Retentive Ring Set
068		Flat EZ Post Cylinder	075		Ball Driver
068		Flat Gold Cylinder	078		Meg-Magnet Abutment
068		Flat CCM Cylinder	078		Meg-Magnet Package
068		Flat Plastic Cylinder	078		Meg-Magnet Attachment Set
072		Overdenture System Meg-Loc Abutment	080		Meg-Rhein Abutment
072		Meg-Loc Package	082		Stainless Steel Housing
072		Meg-Loc Attachment	082		Retentive Caps
072		Multi Tool	083		Stainless Impression Coping
075		Meg-Ball Abutment	083		Lab Analog
075		Meg-Ball Package	083		Retentive Cap Removal Tool

083  Retentive Cap
Insertion Tool

AnyRidge Kit

091  **Abutment Selection
Guide Kit**

092  **Surgical Kit
Full Type**

093  Lance Drill

093  Marking Drill

093  Stopper Drill

094  Point Trepine Bur

094  Trepine Bur

094  Cortical Bone Drill

095  Handpiece
Connector

095  Ratchet Connector

095  Hand Driver

096  Abutment Removal
Driver

096  Drill Extension

096  Direction Indicator

096  Path Finder

096  Torque Wrench
& Adapter
(Included in Surgical Kit,
Prosthetics Kit)

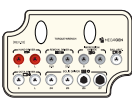
097  **Prosthetic Kit**
(Abutment Removal
Driver, Hand Driver,
Torque Wrench included.)

098  Solid Driver

098  Octa Driver

098  Ball Driver

098  Impression
Coping Driver
(Transfer)

099  **Bone Profiler Kit**

099  Bone Profiler
& Guide pin

100  Right Angle Driver Tip
(Optional Components)

100  Lindermann Drill
(Optional Components)

100  Insert Driver
(Optional)

100  Hand Tap
(Optional)

101  Multi-unit Driver
(Optional)

101  Flattening Drill
(Optional)

101  Manual Inserter
(Optional)

101  Reamer Drill
& Center Pin
(Optional)

102  Trepine Bur
Stopper
(Optional)

102  Bottom Drill
(Optional)

102  Ratchet Wrench
(Optional)

Contents

➔ AnyRidge
010 - 083







➔ AnyRidge Kit
091 - 102

➔ **R2GATE :
Digital Dentistry** >>
104 - 126

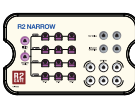



R2GATE Surgical KIT

104		R2GATE Full Surgical Kit for AnyRidge System
106		Initial Drill
106		Second Drill
106		Stopper Drill
106		Bone Profiler
107		Stopper Drill
107		Cortical Bone Drill
107		Implant Carrier
108		Carrier-Handpiece Adapter
108		Carrier Extension
108		Drill Extension
108		Hand Driver
108		Ratchet Wrench

R2GATE Narrow kit

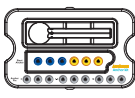
109		R2GATE Narrow Kit
111		Initial Drill
111		Second Drill
111		Stopper Drill
111		Tap Drill
111		Implant Carrier

Anchor Kit

112		Anchor Kit
112		Anchor Pin
113		Stent Anchor
114		Torx Tip
114		Tip Driver

Digital Material

- 123  **Scan Abutment**
- 123  **Scan Abutment**
[C-type]
- 124  **Scan Healing Abutment & Scan Post**
- 124  **Scan Post Carrier**
- 124  **RP Analog**
- 125  **ZrGEN Abutment**
[Standard]
- 126  **ZrGEN Abutment**
[Extra]
- 128  **ZrGEN Abutment**
[C-type]
- 130  **TiGEN Abutment**
[Standard Connection]
- 130  **TiGEN Abutment**
[Extra EZ Connection]



ANYRIDGE®

by MEGA'GEN



Key Advantages

Excellent initial stability even at the compromised bone density

No screw loosening guaranteed!

Unique and valuable ISQ pattern; essential for predictable immediate or early loading.



010 Characteristics & Advantages

- 010 **I. Design Concept**
- 011 **II. Surgery**
- 013 **III. Prosthetics**
- 016 **IV. Maintenance**

017 Fixture Product & Packaging

- 017 **I. Fixture Dimension**
- 019 **II. Fixture Size**
- 022 **III. Packaging**

023 Cover Screw & Healing Abutment

024 Abutment & Prosthetic options

- 024 **I. Fixture Level Prosthesis**
 - 031 1. Extra EZ (S2 Molar) Post
- 039 **II. Abutment Level Prosthesis**
 - 039 1. Solid Abutment & Components
 - 042 2. Octa Abutment & Components
 - 047 3-1. Multi-unit Abutment & Components(N.Type)
 - 063 3-2. Multi-unit Abutment & Components(S.Type)
 - 066 4. Flat Abutment & Components

Abutment & Prosthetic options

069 III. Overdenture Prosthesis

- 069 1. MegaGen Overdenture System
- 070 2. Meg-Loc Abutment & Components
- 073 3. Meg-Ball Abutment & Components
- 076 4. Meg-Magnet Abutment & Components
- 079 5. Meg-Rhein Abutment & Components

085 Clinical Cases

091 AnyRidge Kit

- 091 **I. AnyRidge Abutment Selection Guide Kit**
- 092 **II. AnyRidge Surgical Kit**
 - 092 Standard Type
 - 093 Full Type
 - 094 Surgical Kit Components
- 098 **III. AnyRidge Prosthetic Kit**
 - 099 Prosthetic Kit Components
- 100 **IV. AnyRidge Bone Profiler Kit**
- 101 **V. Optional Components**

Characteristics & Advantages

I. Design Concept

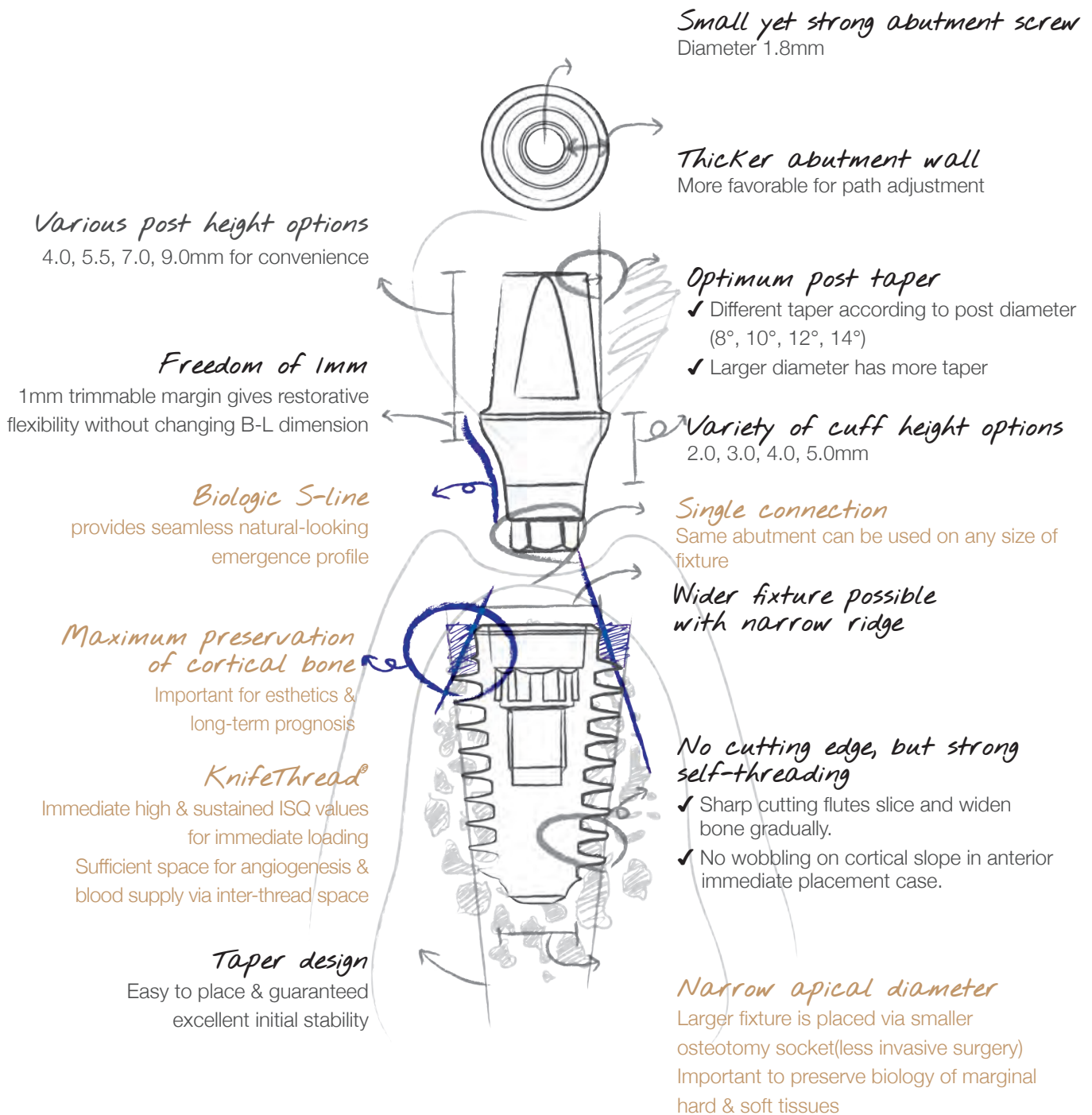

II. Surgery

Excellent initial stability, even at compromised bone density.

AnyRidge® Fixture cuts bone smoothly and condenses it simultaneously.

1. Fixture placement

- **Soft bone**

The super self-tapping threads have a single core diameter that facilitates minimal site preparation by utilizing a smaller osteotomy to place a wider fixture with special threads.

- **Hard bone**

AnyRidge® Fixture with its super self-tapping thread design is easier than other traditional implants at hard bone.

**Caution! : The osteotomy socket (drilling) size should almost reach the size of fixture to avoid getting stuck in the bone during placement.*

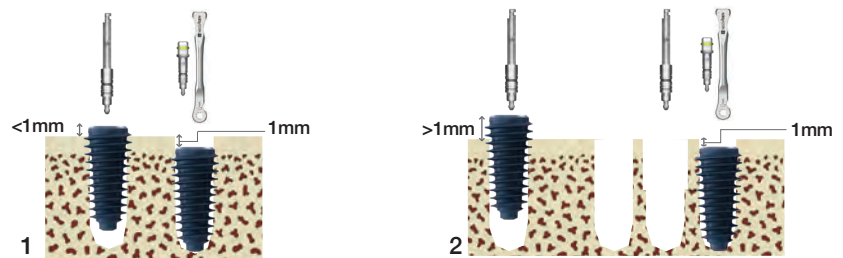

Easy way to avoid stuck in the bone during AnyRidge implant placement

1. Due to extremely strong initial stability of AnyRidge fixture, it can be stuck in the middle during placement especially in mandibular hard bone. Please consider 'One millimeter Rule' to avoid this in the best and easiest way. Clinician can customize the drilling sequence once he fully understand the concept and characteristics of AnyRidge system to get preferred initial stability. 'One millimeter Rule' is simple; if an implant engine (40Ncm) stops leaving one millimeter above the crest, use ratchet wrench to screw it down to preferred position. We recommended to place implant platform 0.5~1.0mm under the crest.

2. If a fixture sticks in the middle leaving more than 1mm above the crest in hard mandibular bone, it is recommended to remove it using a wrench rather than trying to screw it down with excessive torque. Please use a cortical bone drill that is included in a surgical kit, the depth of cortical bone drilling can be adjusted according to the bone condition. Then, place the same fixture into the osteotomy socket.

2. Customized drilling Sequence

- AnyRidge® system has no fixed drilling protocol, just make your own protocol based on patient's bone quality to attain preferred initial stability or simply drill an osteotomy socket to given conditions and then decide the diameter of a fixture.

Example 1) Ø5.0mm fixture can be placed 2.9mm osteotomy socket in D4 bone. Excellent initial stability can be attained



Example 2) In hard one, it is highly recommended to make a socket almost same diameter size as a fixture

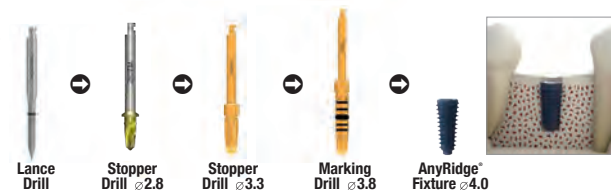

- Improved drill design has simplified drilling sequence, you can even harvest autogenous bone using these specially designed drills.
(Recommended speed : 50 RPM, 50 Ncm with saline solution irrigation)
- The best way to get ideal initial stability with AnyRidge system is placing a fixture using a surgical engine, leaving one or two treads above the crest; then use ratchet wrench to place the platform at the desired position.

III. Prosthetics

Better esthetic outcomes from wide variety of prosthetic options!
 Stop worrying about screw loosening!

1. No screw loosening, less biologic width!

• Magic Five (5° Internal connection)

Now you can be free from screw loosening with our unique connection (5 degree morse taper) which gives perfect hermetic sealing. Biologic width is minimized due to no micro gap, and crestal bone health is well maintained.

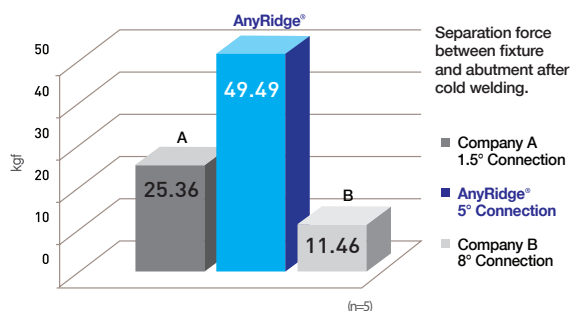

Performed Retention Test to evaluate the fixture-abutment retention force using Universal Testing Machine -R&D center in MegaGen Implant Co.,Ltd.(2009)-

2. Biologic S-line

Helps to achieve beautiful, natural-looking esthetics.

3. Optimum hex height

Feel AnyRidge connection. It starts with impression taking and lasts until final restoration.

4. All indications, various abutment options

Every case, every shape, every size. Everything was considered to satisfy every need.

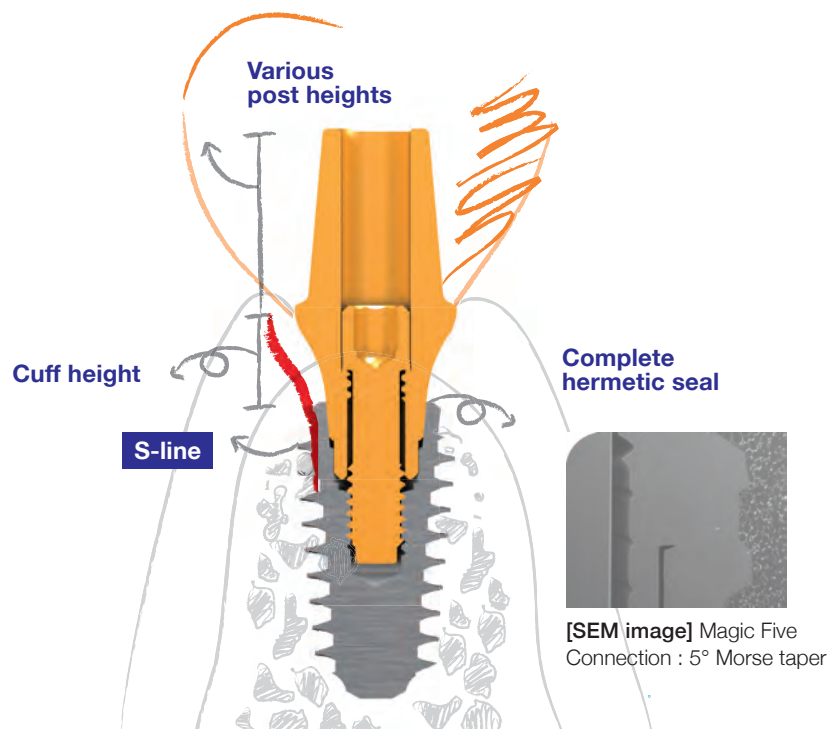

►► Two different connections between a fixture & a component

1. All transitional and temporary components have 'Ledges' on the bottom

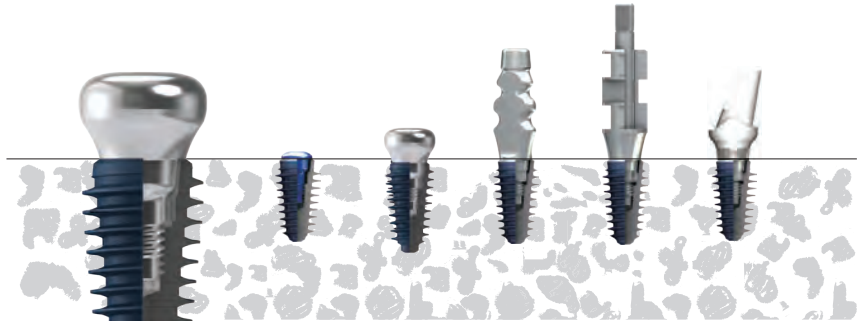

- Cover Screws, Healing Abutments, Impression Coping (transfer and pick-up type), Temporary Cylinders have ledges on the bottom which prevent from cold welding with a fixture.
- Hand Drivers(1.2 Hex) or Impression Drivers can be used easily to screw these components in and out.

2. All permanent abutments will make strong connections with fixtures, even with finger force!

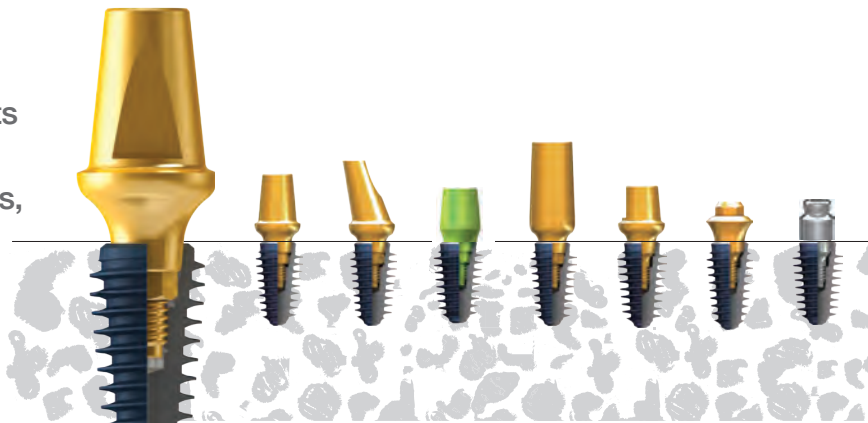

- 25~35Ncm is recommended to connect a permanent abutment into a fixture.
- A fixed abutment cannot be removed with finger force even after complete removal of Abutment Screw because of perfect cold welding. To remove a permanent abutment, Abutment Removal Driver should be used.

►► How to remove Permanent Abutment from Fixture?

Due to extremely strong connection force, you don't have to worry about screw loosening. Please use our special 'removal driver' when you want to remove an abutment from a fixture.

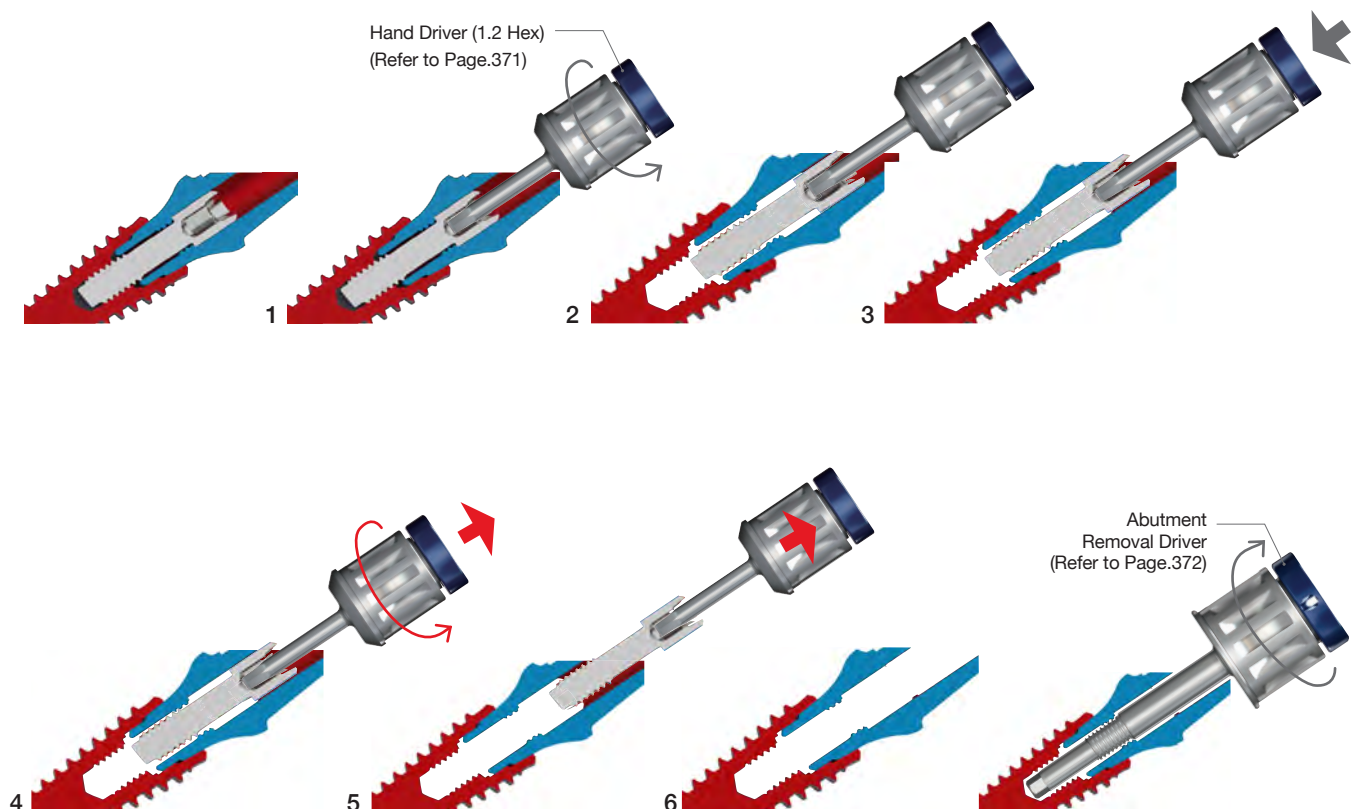

1. Use a Hand Driver(1.2 Hex) to unscrew Abutment Screw.
2. Continue to turn counter-clockwise until you feel a click of disengagement.
3. Push down Hand Driver once again to catch and fix Abutment Screw.
4. Lift up Hand Driver lightly and continue to turn counter-clockwise until Abutment Screw engages with the inner screw of Abutment.
5. Remove Abutment Screw completely from the abutment
6. Insert an 'Abutment Removal Driver' and continue to turn clockwise until the abutment comes out of fixture. You can feel some resistance during screw-down of the Abutment Removal Driver, but don't worry, simple exert is needed disconnect the abutment from the fixture.



IV. Maintenance

Unique and sturdy design provides long-term stability!

1. Higher cortical bone preservation is guaranteed



AnyRidge does not depend on cortical bone for initial stability; decreased stress on cortical bone helps to prevent bone resorption after implantation.

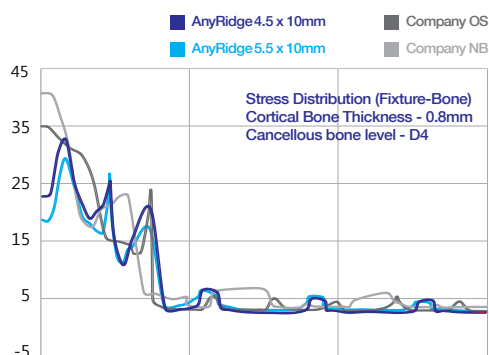

Performed Finite element analysis to evaluate the fixture-bone stress using ABAQUS 6.8 -R&D center in MegaGen Implant Co.,Ltd.(2009)-

- More cortical bone
- = More soft tissue volume
- = Beautiful gingival line

Advanced coronal design allows maximum cortical bone preservation around implants. Beyond osseointegration, AnyRidge can assure beautiful gingival line by preserving and maintaining more cortical bone.

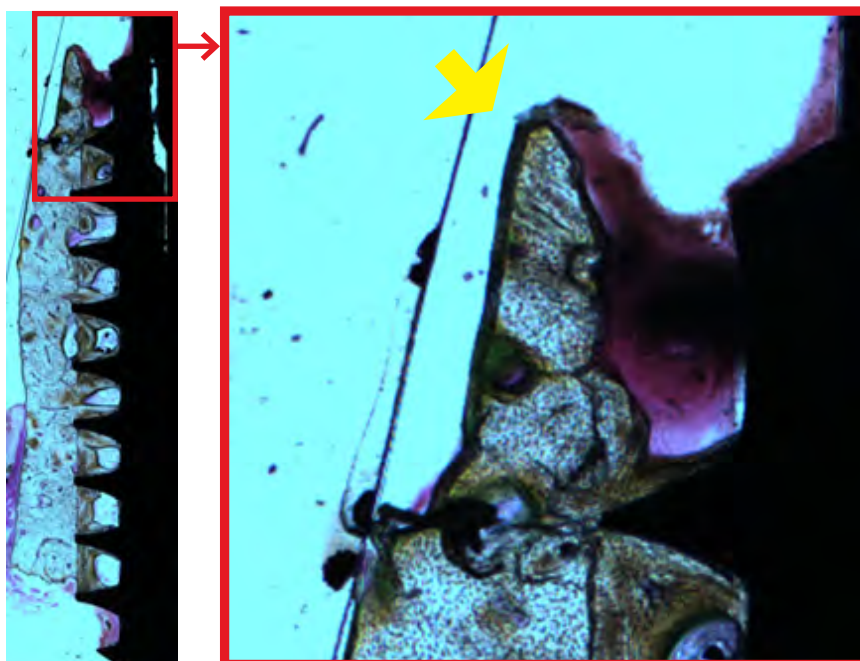

• A Human Biopsy (2.5 yrs after placement)

The sharp and high alveolar crest (yellow arrow) could be maintained due to biology driven implant design. With this maintenance of alveolar bone, the peri-implant marginal gingiva showed almost no recession during 2.5 years of follow-up, even in the case of limited ridge width.



Fixture Product & Packaging

I. Fixture Dimension

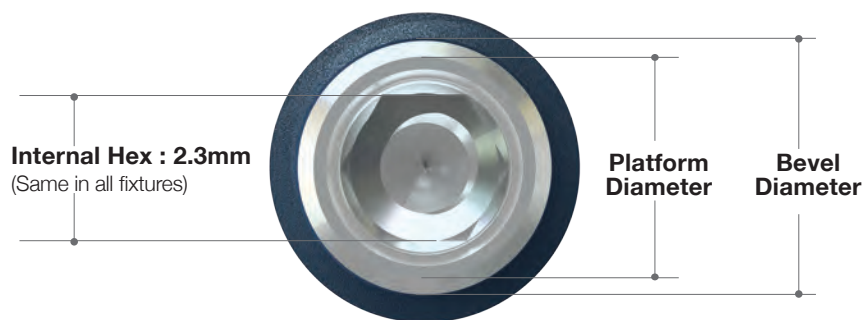

Core (mm)	Platform (mm)	Bevel (mm)
Ø3.3	3.5	3.8
		4.0
Ø3.8	4.0	4.5
Ø4.0	4.25	4.75
Ø4.3	4.5	5.0
Ø4.8	5.0	5.5

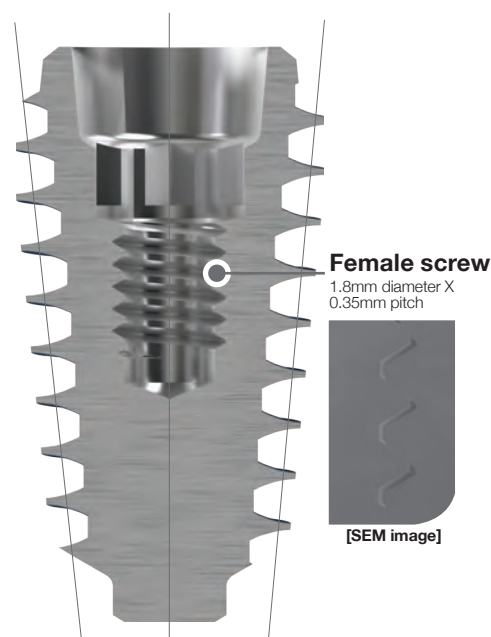
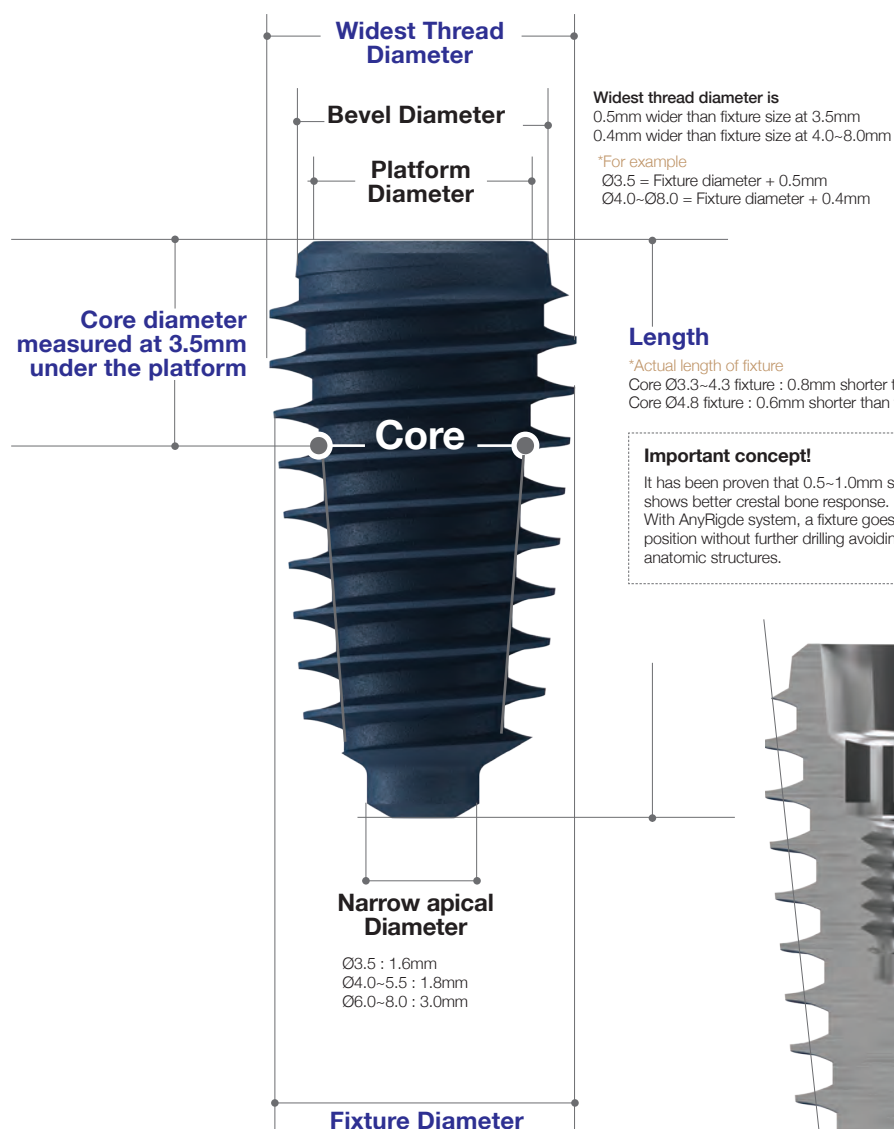













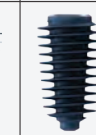





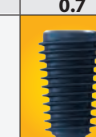

ANYRIDGE® Fixture Line up

Same fixture diameter, yet different core diameters & thread depths

■ Commonly Used Sizes

■ Moral Extraction Options

Core Diameter	Fixture Diameter									
	Ø3.5	Ø4.0	Ø4.5	Ø5.0	Ø5.5	Ø6.0	Ø6.5	Ø7.0	Ø7.5	Ø8.0
Ø2.8										
Thread depth	0.3									
Ø3.3										
Thread depth		0.35	0.6	0.85	1.1					
Ø3.8										
Thread depth			0.35	0.6	0.85					
Ø4.0										
Thread depth				0.45	0.7	0.95				
Ø4.3										
Thread depth				0.35	0.6	0.85				
Ø4.8										
Thread depth					0.35	0.6	0.85	1.1	1.35	1.6

Biologic Molar Solutions

Available Lengths (mm): [7.0, 8.5, 10, 11.5, 13, 15] [7.0, 8.5, 10, 11.5, 13]

*Ø3.5, Ø4.0, Ø4.5 – 18mm option

II. Fixture Size

Small Ø3.5

- Cover Screw included.

- Availability of 7mm product is subject to local approval.

Fixture Diameter (mm)	Core (mm)	Length (mm)	Ref.C
3.5	2.8	8.5	FANIH3508C
		10	FANIH3510C
		11.5	FANIH3511C
		13	FANIH3513C
		15	FANIH3515C



Regular Ø4.0

- Cover Screw included.

- Availability of 7mm product is subject to local approval.

Fixture Diameter (mm)	Core (mm)	Length (mm)	Ref.C
4.0	3.3	8.5	FANIH4008C
		10	FANIH4010C
		11.5	FANIH4011C
		13	FANIH4013C
		15	FANIH4015C



Regular Ø4.5

- Cover Screw included.

- Availability of 7mm product is subject to local approval.

Fixture Diameter (mm)	Core (mm)	Length (mm)	Ref.C
4.5	3.3	7	FANIH4507C
		8.5	FANIH4508C
		10	FANIH4510C
		11.5	FANIH4511C
		13	FANIH4513C
		15	FANIH4515C
	3.8	7	AR384507C
		8.5	AR384508C
		10	AR384510C
		11.5	AR384511C
		13	AR384513C
15	AR384515C		



➔ Fixture Size (Continued)

Wide Ø5.0

- Cover Screw included.

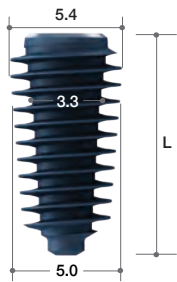

Fixture Diameter (mm)	Core (mm)	Length (mm)	Ref.C
5.0	3.3	7	FANIH5007C
		8.5	FANIH5008C
		10	FANIH5010C
		11.5	FANIH5011C
		13	FANIH5013C
		15	FANIH5015C
	3.8	7	AR385007C
		8.5	AR385008C
		10	AR385010C
		11.5	AR385011C
		13	AR385013C
		15	AR385015C

Fixture Diameter (mm)	Core (mm)	Length (mm)	Ref.C
5.0	4.0	7	FANIH5007SC
		8.5	FANIH5008SC
		10	FANIH5010SC
		11.5	FANIH5011SC
		13	FANIH5013SC
		15	FANIH5015SC
	4.3	7	AR435007C
		8.5	AR435008C
		10	AR435010C
		11.5	AR435011C
		13	AR435013C
		15	AR435015C

Wide Ø5.5

- Cover Screw included.

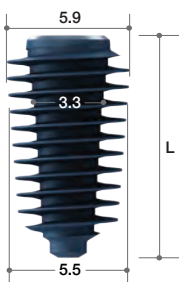

Fixture Diameter (mm)	Core (mm)	Length (mm)	Ref.C
5.5	3.3	7	FANIH5507C
		8.5	FANIH5508C
		10	FANIH5510C
		11.5	FANIH5511C
		13	FANIH5513C
		15	FANIH5515C
	3.8	7	AR385507C
		8.5	AR385508C
		10	AR385510C
		11.5	AR385511C
		13	AR385513C
		15	AR385515C
	4.0	7	FANIH5507SC
		8.5	FANIH5508SC
		10	FANIH5510SC
		11.5	FANIH5511SC
		13	FANIH5513SC
		15	FANIH5515SC

Fixture Diameter (mm)	Core (mm)	Length (mm)	Ref.C
5.5	4.3	7	AR435507C
		8.5	AR435508C
		10	AR435510C
		11.5	AR435511C
		13	AR435513C
		15	AR435515C
	4.8	7	AR485507C
		8.5	AR485508C
		10	AR485510C
		11.5	AR485511C
		13	AR485513C
		15	AR485515C

➔ Fixture Size

Super Wide Ø6.0

- Cover Screw included.

Fixture Diameter (mm)	Core (mm)	Length (mm)	Ref.C
6.0	4.0	7	AR406007C
		8.5	AR406008C
		10	AR406010C
		11.5	AR406011C
		13	AR406013C
	4.3	7	AR436007C
		8.5	AR436008C
		10	AR436010C
		11.5	AR436011C
		13	AR436013C
	4.8	7	FALHX6007C
		8.5	FALHX6008C
		10	FALHX6010C
		11.5	FALHX6011C
		13	FALHX6013C



Super Wide Ø6.5

- Cover Screw included.

Fixture Diameter (mm)	Core (mm)	Length (mm)	Ref.C
6.5	4.8	7	FALHX6507C
		8.5	FALHX6508C
		10	FALHX6510C
		11.5	FALHX6511C
		13	FALHX6513C



Super Wide Ø7.0

- Cover Screw included.

Fixture Diameter (mm)	Core (mm)	Length (mm)	Ref.C
7.0	4.8	7	FALHX7007C
		8.5	FALHX7008C
		10	FALHX7010C
		11.5	FALHX7011C
		13	FALHX7013C



Super Wide Ø7.5

- Cover Screw included.

Fixture Diameter (mm)	Core (mm)	Length (mm)	Ref.C
7.5	4.8	7	FALHX7507C
		8.5	FALHX7508C
		10	FALHX7510C
		11.5	FALHX7511C
		13	FALHX7513C

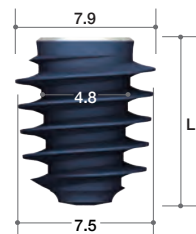

Super Wide Ø8.0

- Cover Screw included.

Fixture Diameter (mm)	Core (mm)	Length (mm)	Ref.C
8.0	4.8	7	FALHX8007C
		8.5	FALHX8008C
		10	FALHX8010C
		11.5	FALHX8011C
		13	FALHX8013C

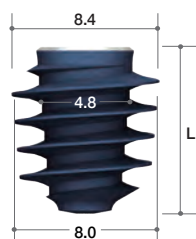

III. Packaging

- Ampule

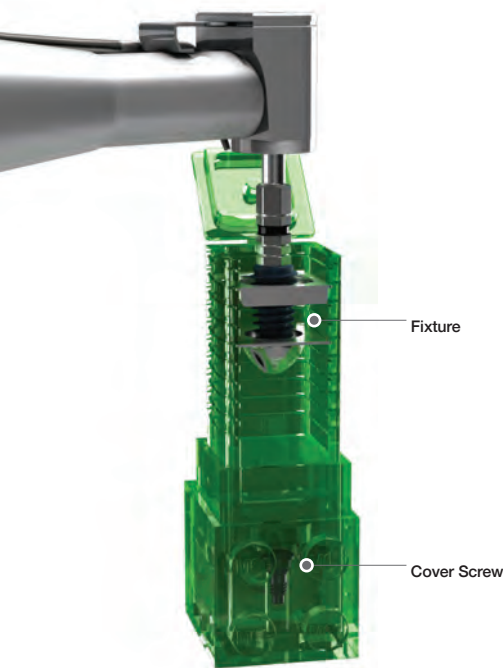

Peel off cover & remove ampule

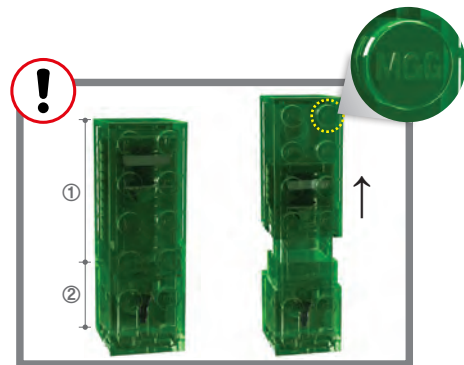

Separate top[®] & bottom[®], as shown, to reveal inner ampule with fixture



Flip open top to reveal fixture



Connect handpiece to fixture



Make sure fixture is fully connected, then remove from ampule

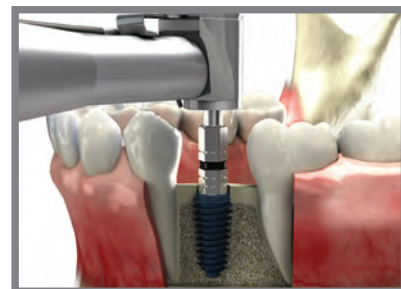

Place fixture according to drilling sequence



Separate fixture ampule from bottom, as shown, to reveal cover screw holder[®]



Use hand driver to pick up cover screw



Tighten cover screw to fixture

MegaGen ampule! Re-usable as building block *after cleaning and sterilization! less plastic waste!

Cover Screw & Healing Abutment

Cover Screw

* Included in the fixture package.

- Use with a Hand Driver(1.2 Hex).
- Used for submerged type surgery.
- Protects the inner structure of a fixture.
- Different heights can be chosen according to the position of fixture below the crest.
- 1.6mm and 2.6mm height of Cover Screw can be purchased separately.
- Recommend torque : by hand (5 - 8Ncm)

Profile Diameter	Height (mm)	Ref.C
Ø3.5	0.8	AANCSF3508
	1.6	AANCSF3516
	2.6	AANCSF3526
Ø5.0	0.5	AANCSF5005
Ø6.0	0.5	AANCSF6005

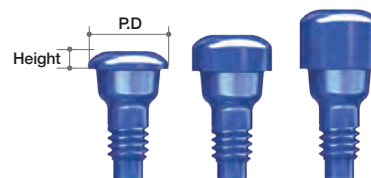

Healing Abutment

- Use with a Hand Driver(1.2 Hex).
- Used for non-submerged type surgery or for two stage surgery.
- Choose appropriate diameter and height of Healing Abutment according to situation.
- Helps to form suitable emergence profile during period of gingival healing.
- Recommend torque : by hand (5 - 8Ncm)

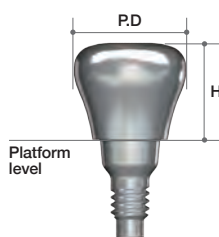

Profile Diameter	Height (mm)	Ref.C
Ø4.0	3	AANHAF0403
	4	AANHAF0404
	5	AANHAF0405
	6	AANHAF0406
	7	AANHAF0407
	8	AANHAF0408
	9	AANHAF0409
Ø5.0	3	AANHAF0503
	4	AANHAF0504
	5	AANHAF0505
	6	AANHAF0506
	7	AANHAF0507
	8	AANHAF0508
	9	AANHAF0509
Ø6.0	3	AANHAF0603
	4	AANHAF0604
	5	AANHAF0605
	6	AANHAF0606
	7	AANHAF0607
	8	AANHAF0608
	9	AANHAF0609

Profile Diameter	Height (mm)	Ref.C
Ø7.0	3	AANHAF0703
	4	AANHAF0704
	5	AANHAF0705
	6	AANHAF0706
	7	AANHAF0707
	8	AANHAF0708
	9	AANHAF0709
Ø8.0	3	AANHAF0803
	4	AANHAF0804
	5	AANHAF0805
	6	AANHAF0806
	7	AANHAF0807
	8	AANHAF0808
	9	AANHAF0809
Ø10.0	3	AANHAF1003
	4	AANHAF1004
	5	AANHAF1005
	6	AANHAF1006
	7	AANHAF1007
	8	AANHAF1008
	9	AANHAF1009

Abutment & Prosthetic Options

I. Fixture Level Prosthesis

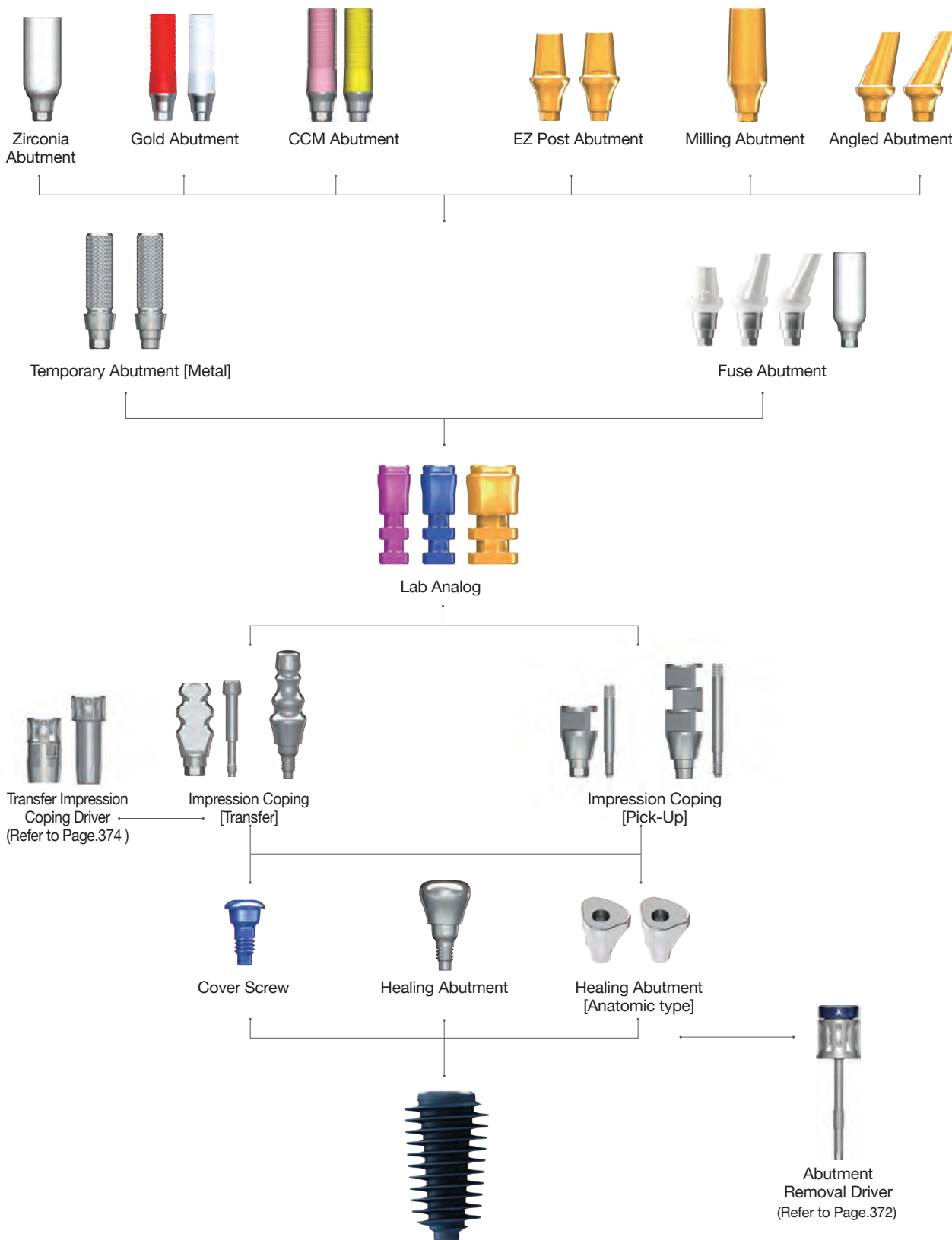

➔ Impression Copings

Impression Coping

(2-piece, Transfer Type)
(For Closed-tray Technique)

- Guide Pins : AANGPT/AANGPT12H/AANGPT16/
AANGPT16H) included.

- Streamlined shape ; easy to transfer.
- Anti-rotation grooves match with hex structure of fixtures.
- Should be tightened with Impression Coping Driver (Page.374)
- Impression Coping Driver and Hand Driver(1.2Hex) should be used to ensure Impression Coping is properly tightened.

Profile Diameter	Height (mm)	Type	Ref.C
Ø4.0	12	2-Piece	AANITH4012T
	16		AANITH4016T
Ø5.0	12		AANITH5012T
	16		AANITH5016T
Ø4.0	12	2-Piece Hand driver (1.2 Hex)	AANITH4012HT
	16		AANITH4016HT
Ø5.0	12		AANITH5012HT
	16		AANITH5016HT

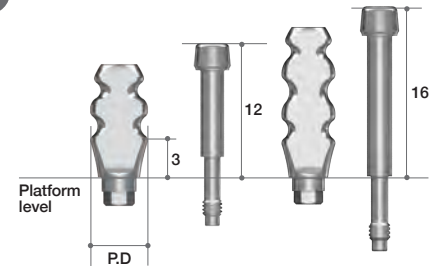

Impression Coping

(1-piece, Transfer Type)
(For Closed-tray Technique)

- Should be tightened with Impression Coping Driver (Page.374)
- Impression Coping Driver and Hand Driver(1.2Hex) should be used to ensure Impression Coping is properly tightened.

Profile Diameter	Height (mm)	Type	Ref.C
Ø4.0	12	1-Piece	AANITN4012
	16		AANITN4016
Ø5.0	12		AANITN5012
	16		AANITN5016
Ø4.0	12	1-Piece Hand driver (1.2 Hex)	AANITN4012H
	16		AANITN4016H
Ø5.0	12		AANITN5012H
	16		AANITN5016H

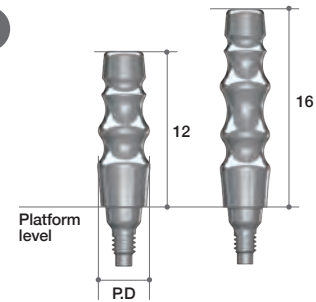

Impression Coping

(2-piece, Pick-up Type)
(For Open-tray Technique)

- Guide Pins : AANGPP0010 (7mm : Short) /
AANGPP0015 (12mm : Long) / AANGPP0020
(20mm : Extra-long)

- Square structure ; strong anti - rotation function.
- Designed for easy and accurate pick-up impression.
- Extra-long guide pin can be purchased separately.

Profile Diameter	Height (mm)	Type	Ref.C
Ø4.0	12	2-Piece	AANIPH4012T
	16		AANIPH4016T
	12		AANIPN4012T
	16		AANIPN4016T
Ø5.0	7		AANIPH5007T
	12		AANIPH5012T
	7		AANIPN5007T
	12		AANIPN5012T

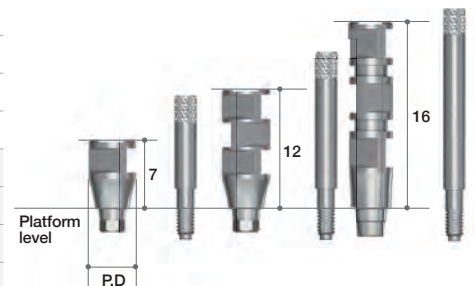

➔ Lab Analog & Temporary Abutment

Lab Analog

Profile Diameter	Color	Ref.C
Ø3.5	Magenta	AANLAF35
Ø4.0 ~ Ø5.5	Blue	AANLAF4055
Ø6.0 ~ Ø8.0	Yellow	AALLAF6080



Temporary Abutment (Titanium)

- Multi Post Screw(AANMSF) included.
- For making provisional restoration.
- Grooved on the post allows strong resin adherence.
- Recommend torque : 25Ncm

Profile Diameter	Cuff Height (mm)	Type	Ref.C
Ø4.0	2	Hex	AANTMH4012T
		Non-Hex	AANTMN4012T

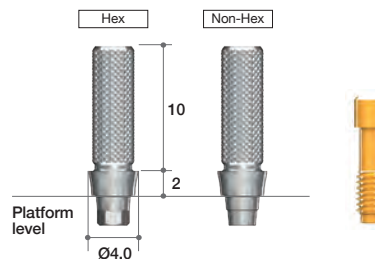

Fuse Abutment

- Straight, 15°, 25° ; Multi Post Screw(AANMSF) included + Fuse Cap included.
- Milling ; Multi Post Screw(AANMSF) included.
- Recommend torque : 25Ncm

Diameter	C.H (mm)	P.H (mm)	Type	Ref.C
Ø5.5	4	5.5	Straight	AFAP5545P
			15°	AFAA5415P
	25°	AFAA5425P		
Ø5.0	1	11	Milling	AANTAH5012T

NEW : 4mm cuff height available
 → Adequate for deeply placed implants
 or thick gingival cases

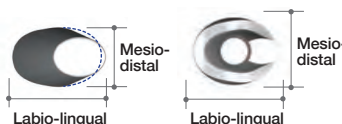
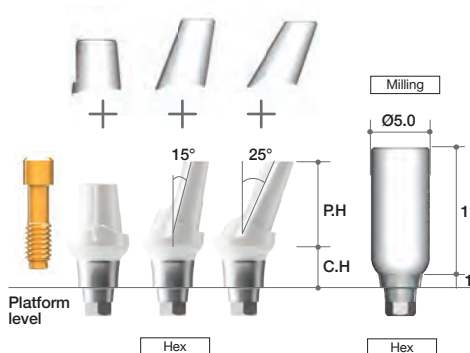

► **Fuse Abutment™**



Why is the 'Fuse Abutment' essential partner for a temporary crown?

Design concept of Fuse Abutment™



Similar to a customized abutment for excellent esthetics!

Perfect margin fit with a prosthetic cap

Scalloped outline

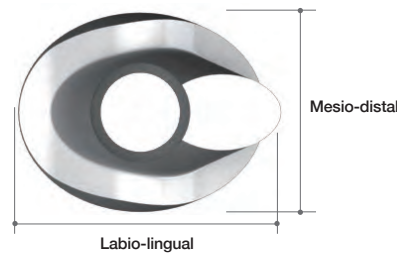

Elliptical Occlusal view like a natural tooth



Rationale of Fuse Abutment™

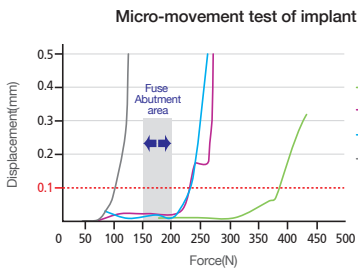

Performed compressive strength test to evaluate the micro movement for bone density using universal testing machine -R&D center in Megagen Implant Co.,Ltd.(2012)-

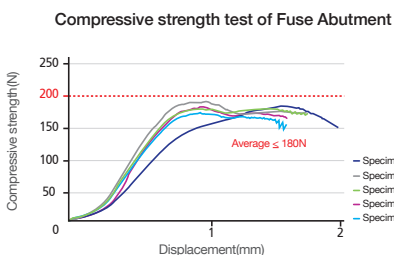

Performed compressive strength test to evaluate the yield strength for Fuse Abutment using universal testing machine -R&D center in Megagen Implant Co.,Ltd.(2012)-

In 1992, Brunski JB. reported that the implant may has a higher possibility of fibrointegration than osseointegration between bone and implant surface when movements of more than 100µm occur on the fixture during osseointegration period. (John B. Brunski, Biomechanical factors affecting the bone-dental implant interface. Clinical Materials, Vol. 10, 153-201) Therefore, the implant was needed to protected not to move when immediate loading is carried out. However, it is not easy to manage loading on the fixture, even when we used a resin temporarily with a titanium cylinder. It was thought that it was partly because of the metal component of temporary cylinder, which can deliver excessive forces to the fixture. This was one of the reasons which made clinicians hesitate the immediate loading procedure. So it was necessary to develop a special temporary cylinder. It should have been broken under the force which could lead fibrointegration or failure of osseointegration to protect the fixture. and it would be preferred if it was easy to make a temporary crown on this particular temporary cylinder. We tried to measure the force causing movement

of 100µm on a fixture which was placed securely into adequate density of bone without defect. First, AnyRidge implants were placed into the internationally recognized standard bone block with more 40Ncm torque force and an abutment was connected on each implant. Instron equipment was used to measure the force to move a fixture 100µm. The average force was 220N (22.4 kgf). Therefore, if the new temporary abutment can be fractur under this force, it might protect the fixture from movement or failure.

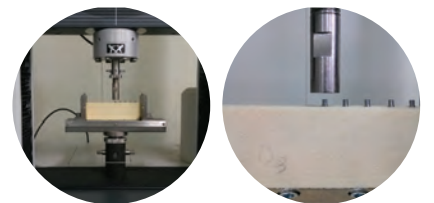

From this experiment, we could developed a special temporary abutment which has lower fracture threshold of less than 200 N (20.4 kgf). It was named as Fuse Abutment. Also it has an anatomic profiles to make temporary prosthetics more esthetic.

➔ Abutment Options (Continued)

EZ Post Abutment

- Multi Post Screw(AANMSF/AANMST) included.

- Use with a Hand Driver (1.2 Hex).
- Esthetic gold coloring.
- Two different post heights. (5.5, 7.0mm)
- Four different profile diameters. (Ø4.0, 5.0, 6.0, 7.0)
- Four different cuff heights. (2.0, 3.0, 4.0, 5.0mm)
- Recommend torque : 35Ncm

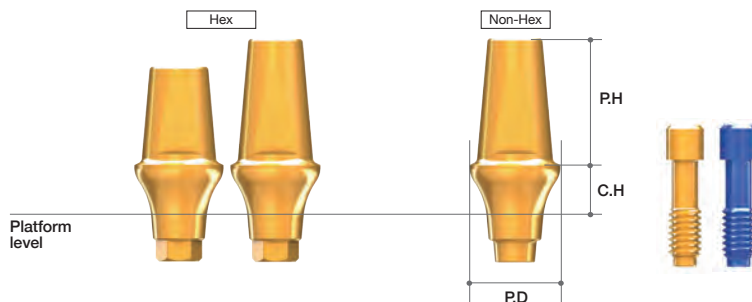

Profile Diameter	Cuff Height(mm)	Post Height(mm)	Type	Ref.C
Ø4.0	2	5.5	Hex	AANEPH4025L
	3			AANEPH4035L
	4			AANEPH4045L
	5			AANEPH4055L
	2	7		AANEPH4027L
	3			AANEPH4037L
	4			AANEPH4047L
	5			AANEPH4057L
Ø4.0	2	5.5	Non-Hex	AANEPN4025L
	3			AANEPN4035L
	4			AANEPN4045L
	5			AANEPN4055L
	2	7		AANEPN4027L
	3			AANEPN4037L
	4			AANEPN4047L
	5			AANEPN4057L
Ø5.0	2	5.5	Hex	AANEPH5025L
	3			AANEPH5035L
	4			AANEPH5045L
	5			AANEPH5055L
	2	7		AANEPH5027L
	3			AANEPH5037L
	4			AANEPH5047L
	5			AANEPH5057L
Ø5.0	2	5.5	Non-Hex	AANEPN5025L
	3			AANEPN5035L
	4			AANEPN5045L
	5			AANEPN5055L
	2	7		AANEPN5027L
	3			AANEPN5037L
	4			AANEPN5047L
	5			AANEPN5057L

Profile Diameter	Cuff Height(mm)	Post Height(mm)	Type	Ref.C
Ø6.0	2	5.5	Hex	AANEPH6025L
	3			AANEPH6035L
	4			AANEPH6045L
	5			AANEPH6055L
	2	7		AANEPH6027L
	3			AANEPH6037L
	4			AANEPH6047L
	5			AANEPH6057L
Ø6.0	2	5.5	Non-Hex	AANEPN6025L
	3			AANEPN6035L
	4			AANEPN6045L
	5			AANEPN6055L
	2	7		AANEPN6027L
	3			AANEPN6037L
	4			AANEPN6047L
	5			AANEPN6057L
Ø7.0	2	5.5	Hex	AANEPH7025L
	3			AANEPH7035L
	4			AANEPH7045L
	5			AANEPH7055L
	2	7		AANEPH7027L
	3			AANEPH7037L
	4			AANEPH7047L
	5			AANEPH7057L
Ø7.0	2	5.5	Non-Hex	AANEPN7025L
	3			AANEPN7035L
	4			AANEPN7045L
	5			AANEPN7055L
	2	7		AANEPN7027L
	3			AANEPN7037L
	4			AANEPN7047L
	5			AANEPN7057L

➔ Abutment Options (Continued)

Gold Abutment

- Multi Post Screw(AANMSF/AANMST) included.

- Useful to make a customized abutment in difficult situations.
- Precious and non-precious alloys.
- Melting point of gold alloy : 1063°C
- Threaded sleeves for convenient Resin / Wax-up.
- Recommend torque : 30Ncm

Profile Diameter	Cuff Height(mm)	Post Height(mm)	Type	Ref.C
Ø4.0	1	11	Hex	AANGAH4012L
			Non-Hex	AANGAN4012L

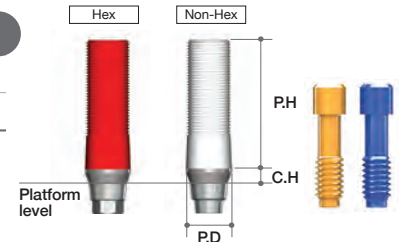

Zirconia Abutment

- Multi Post Screw(AANMSF/AANMST) included.

- For esthetic use.
- Natural white color with pre-sintered zirconia sleeve.
- Presinpered Zircornia Abutment.
- Preparable at the chair side with a diamond bur.
- Recommend torque : 35Ncm

Profile Diameter	Cuff Height(mm)	Post Height(mm)	Type	Ref.C
Ø4.0	1	11	Hex	AANZAH4012L
Ø5.0				AANZAH5012L

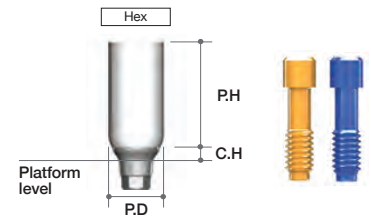

Milling Abutment

- Multi Post Screw(AANMSF/AANMST) included.

- Long post enables easier customization from milling.
- Recommend torque : 35Ncm

Profile Diameter	Cuff Height(mm)	Post Height(mm)	Ref.C
Ø4.0	2	9	AANMAH4029L
	3		AANMAH4039L
	4		AANMAH4049L
	5		AANMAH4059L
Ø5.0	2	9	AANMAH5029L
	3		AANMAH5039L
	4		AANMAH5049L
	5		AANMAH5059L
Ø6.0	2	9	AANMAH6029L
	3		AANMAH6039L
	4		AANMAH6049L
	5		AANMAH6059L
Ø7.0	2	9	AANMAH7029L
	3		AANMAH7039L
	4		AANMAH7049L
	5		AANMAH7059L

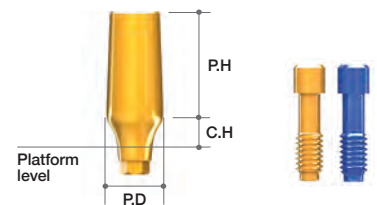

➔ Abutment Options (Continued)

Angled Abutment

- Multi Post Screw(AANMSF/AANMST) included.

- Two different angulations. (15°, 25°)
- Four different profile diameters. (Ø4.0, 5.0, 6.0, 7.0)
- Four different cuff heights. (2, 3, 4, 5mm)
- Can cover 12 different directions. [six to the surface(Hex), six to the edge of hex(Hex-E)]
- Esthetic gold coloring.
- Minimized screw head length needs minimum height to prevent milling problems.
- Recommend torque : 35Ncm

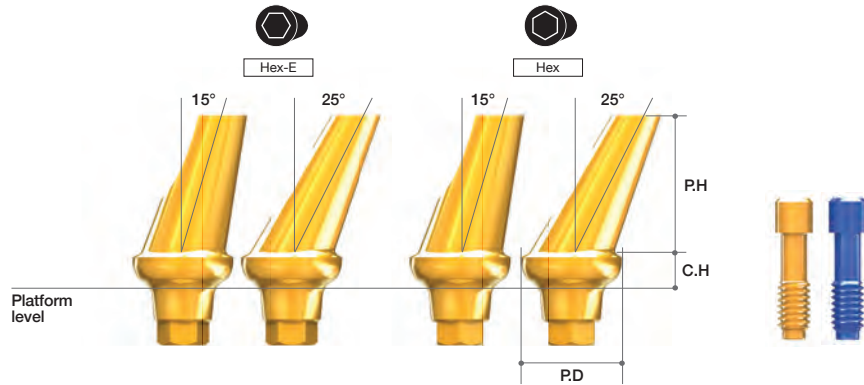

Profile Diameter	Cuff Height(mm)	Post Height(mm)	Type	Angle	Ref.C
Ø4.0	2	7	Hex	15°	AANAAH4215L
	3				AANAAH4315L
	4				AANAAH4415L
	5				AANAAH4515L
	2				AANAAE4215L
	3				AANAAE4315L
	4				AANAAE4415L
	5				AANAAE4515L
	2		Hex	25°	AANAAH4225L
	3				AANAAH4325L
	4				AANAAH4425L
	5				AANAAH4525L
	2				AANAAE4225L
	3				AANAAE4325L
	4				AANAAE4425L
	5				AANAAE4525L
Ø5.0	2	7	Hex	15°	AANAAH5215L
	3				AANAAH5315L
	4				AANAAH5415L
	5				AANAAH5515L
	2				AANAAE5215L
	3				AANAAE5315L
	4				AANAAE5415L
	5				AANAAE5515L
	2		Hex	25°	AANAAH5225L
	3				AANAAH5325L
	4				AANAAH5425L
	5				AANAAH5525L
	2				AANAAE5225L
	3				AANAAE5325L
	4				AANAAE5425L
	5				AANAAE5525L

Profile Diameter	Cuff Height(mm)	Post Height(mm)	Type	Angle	Ref.C
Ø6.0	2	7	Hex	15°	AANAAH6215L
	3				AANAAH6315L
	4				AANAAH6415L
	5				AANAAH6515L
	2				AANAAE6215L
	3				AANAAE6315L
	4				AANAAE6415L
	5				AANAAE6515L
	2		Hex	25°	AANAAH6225L
	3				AANAAH6325L
	4				AANAAH6425L
	5				AANAAH6525L
	2				AANAAE6225L
	3				AANAAE6325L
	4				AANAAE6425L
	5				AANAAE6525L
Ø7.0	2	7	Hex	15°	AANAAH7215L
	3				AANAAH7315L
	4				AANAAH7415L
	5				AANAAH7515L
	2				AANAAE7215L
	3				AANAAE7315L
	4				AANAAE7415L
	5				AANAAE7515L
	2		Hex	25°	AANAAH7225L
	3				AANAAH7325L
	4				AANAAH7425L
	5				AANAAH7525L
	2				AANAAE7225L
	3				AANAAE7325L
	4				AANAAE7425L
	5				AANAAE7525L

CCM Abutment

- Multi Post Screw(AANMSF/AANMST) included.

- Useful to make a customized abutment in difficult situations.
- Can be casted with non-precious alloys (Ni-Cr, Cr-Co alloys).
- Non-precious melting temperature : Depend on Manufacturer
- Threaded sleeves for convenient Resin / Wax-up.
- Melting temperature of CCM : 1300~1400°C
- Recommend torque : 35Ncm

Profile Diameter	Cuff Height(mm)	Post Height(mm)	Type	Ref.C
Ø4.0	1	11	Hex	AANCAH4012L
			Non-Hex	AANCAN4012L

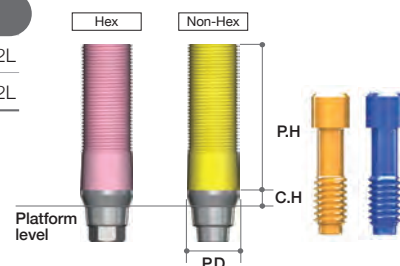

I. Fixture Level Prosthesis

1. Fixture Level Prosthesis_ Extra EZ (S2 Molar) Post

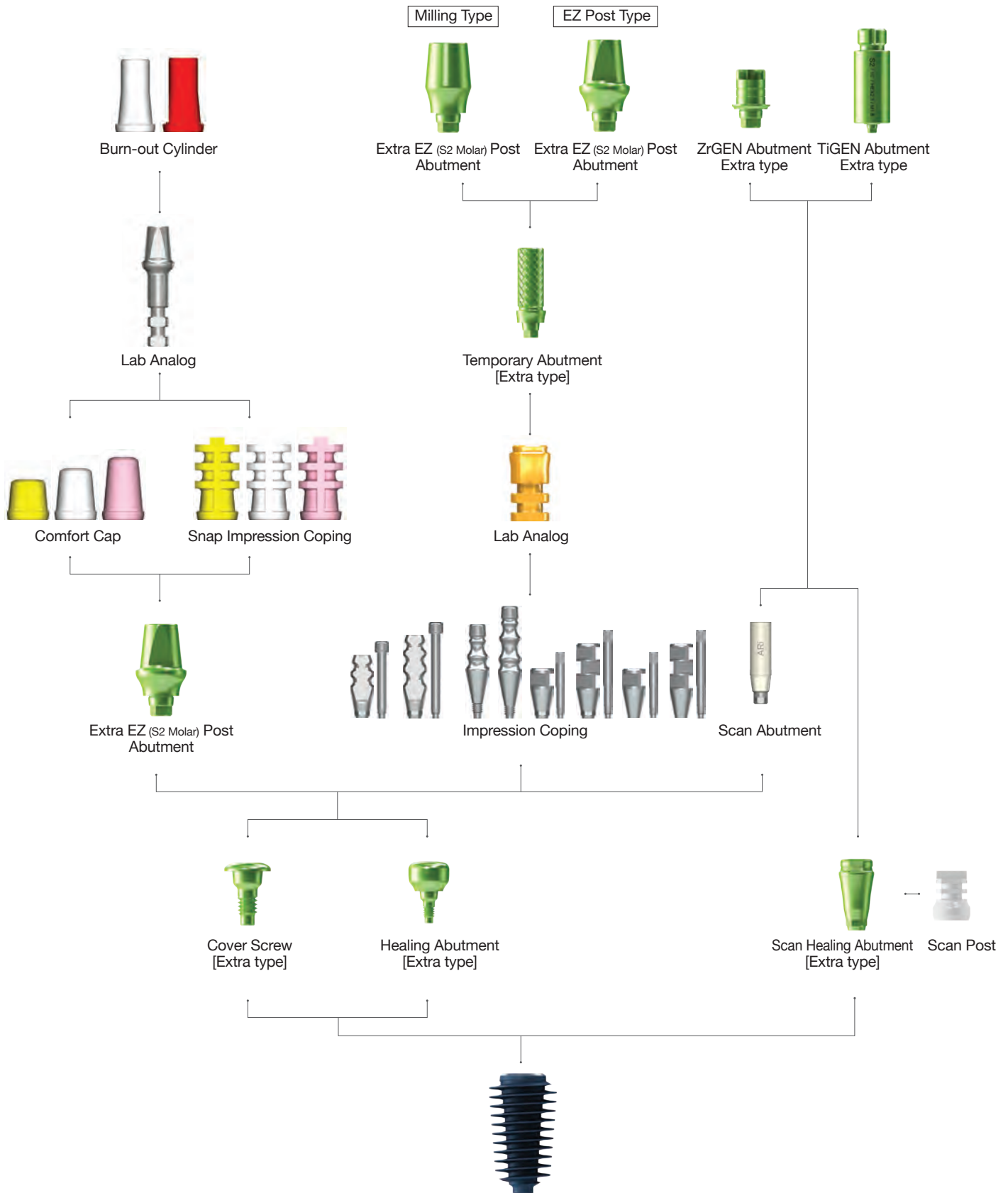

S2 Option for successful 'S2 molar implant'

AnyRidge challenges to the HIGH SURVIVAL RATE even at the S2 molar

S2 molar implants have a much lower success rate than other implants

1) Simple Literature Review:

General implant success rate
99.7% 10-year survival rate
 - van Velzen FJ et al. (2014)
95.6%, 94.4%, 96.1%, 100%, 90.6%, 95.7% - CSR of 759 implants in single-tooth prostheses, cantilever fixed, partial prostheses, fixed partial prostheses, fixed complete prostheses, implant/tooth-connected prostheses, and overdentures - Romeo E et al. (2004)

S2 molar implant success rate
89.0% CSR for 392 implants in posterior mandible for 6 yrs - Parein et al. (1997)
91.1% 2nd molar survival rate for 2 yrs - YK kim et al. (2010)
82.9%, 91.5% Prospective study on 282 implants placed in Mx and Mn molar positions (6 years cumulative study) Becker et al. (1999)
8.16% failure in the Mx, **4.93%** failure in Mn - Moy et al (2005)

Problem

2) Why less success rate at the S2 Molar?

Handicaps of the S2 Molar Implant ;

- 1. Less quality & quantity of alveolar bone**
 - Maxillary 2nd Molar site usually show less quality (Type IV or worse) and/or limited height due to Sinus pneumatization.
 - Mandible 2nd Molar site usually show less blood supply which is important for adequate alveolar bone metabolism. And limited height of bone due to the inferior mandibular nerve.
- 2. Strong Occlusal force**
 Due to special joint system at TMJ, the S2 Molar usually endure strong occlusal force during mastication.
- 3. Hygiene Problem**
 Due to remote position, it's very difficult to maintain hygiene at the S2 Molar, especially at the distal area, So easy to get peri-implantitis than others.

Solution

3) How to overcome less success rate?

Possible solution

- We need an implant system which can provide **excellent initial stability**® even at the loose bone and limited height of bone.
- We need an implant system which can provide **enough surface area**® for osseointegration, even at the limited height of bone.
- We need to provide **enough space for angiogenesis and blood supply**® for more active bone remodeling.

We need **stronger implant fixture and abutment connection**® to withstand occlusal forces and lateral movement.

We need to choose **adequate material**® for abutment and crown, which retains much less plaque, even with less accessibility and hygiene skills.

4) MegaGen's suggestion for the S2 molar implant

“S2 Option” strongly recommended by KOLs of MegaGen.

- ① Excellent initial stability at loose bone
 - ② Enough surface area for osseointegration
- Already well-know advantages of AnyRidge Implant System.



“S2 Option”
 1. Less quality & quantity of alveolar bone

thread	length (mm)	S2 surface (mm²)	S2 surface (mm²)
1 st	1.0	15,739	15,739
2 nd	1.8	41,950	43,013
3 rd	2.6	72,262	84,771
4 th	3.4	102,739	123,85
5 th	4.2	132,213	164,971
6 th	5.0	160,362	197,971
7 th	5.8	187,153	232,033
8 th	6.6	212,613	268,709
9 th	7.2	230,851	289,492
10 th	8.0	253,917	319,185
Apex	8.8	268,933	331,493

EZ plus surface area (mm²)

04.0 X 7	130,613
04.0 X 8	130,961
04.0 X 10	164,734
06.0 X 7	170,520
06.0 X 8	182,268
06.0 X 10	214,768

[Surface area comparison between AnyRidge and EZ plus]

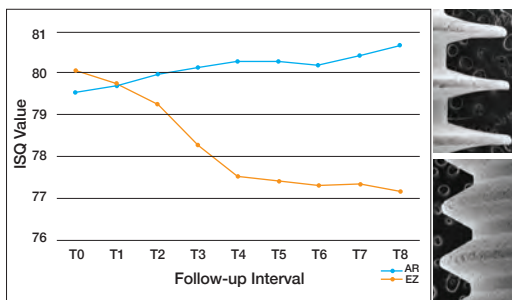

[ISQ value comparison between AnyRidge and EZ plus]

S2 molar implants have a much lower success rate than other implants

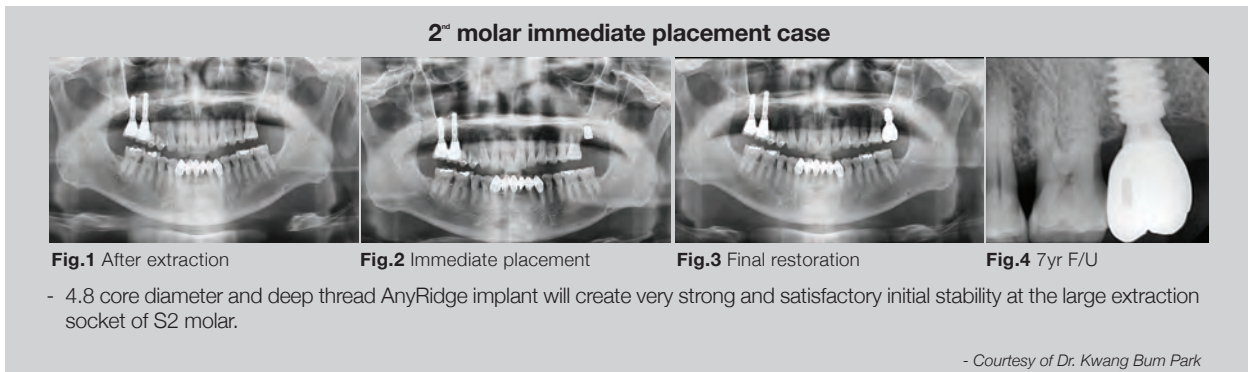

③ Enough space for angiogenesis and blood supply through the inter-thread space

- Knife thread design of AnyRidge implant creates the maximum space for blood supply

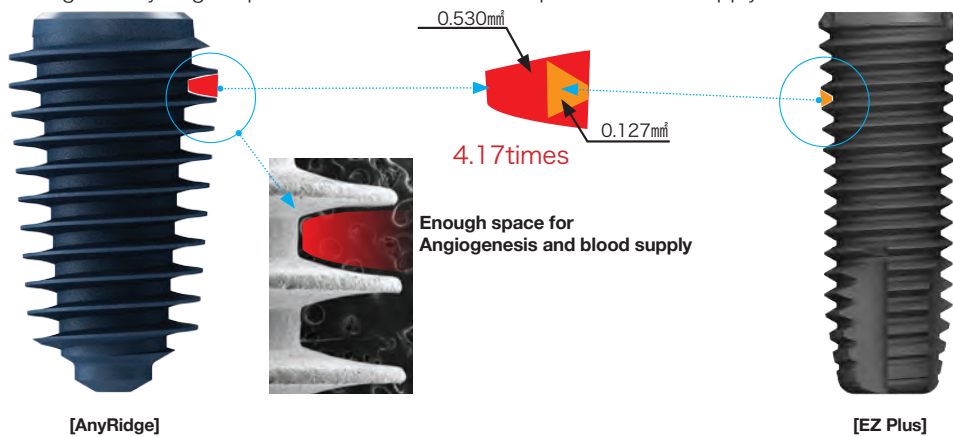

④ Stronger fixture and abutment connection

Fixture selection

- As minimum, use **3.8mm core diameter AnyRidge implant**
- If enough bone width, use **4.3mm or 4.8mm core diameter AnyRidge implant**
- For large extraction socket, use **4.8mm core diameter & deep thread AnyRidge implant**

Core Diameter	Fixture Diameter									
	Ø3.5	Ø4.0	Ø4.5	Ø5.0	Ø5.5	Ø6.0	Ø6.5	Ø7.0	Ø7.5	Ø8.0
Ø2.8										
Thread depth	0.3									
Ø3.3										
Thread depth		0.35	0.6	0.85	1.1					
Ø3.8										
Thread depth			0.35	0.6	0.85					S2 Option
Ø4.0										
Thread depth				0.45	0.7	0.95				
Ø4.3										
Thread depth				0.35	0.6	0.85				
Ø4.8										
Thread depth					0.35	0.6	0.85	1.1	1.35	1.6

Refer to page. 018

Abutment selection

- 5° AnyRidge connection is really strong & shows almost no biological width
- Double offset (implant switching & abutment switching) is very helpful to improve soft tissue esthetics & health
- However, for S2 molar implant, strength against lateral occlusal force is more critical than esthetics
- So, for second molar abutment, **use Extra EZ (S2 Molar) Connection**

[Normal connection]

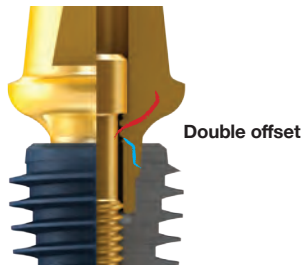

Compressive strength is improved by **67%**

[S2 Option : Double connection]

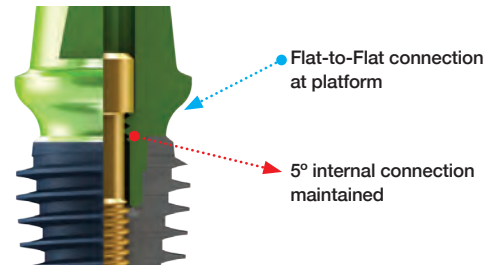

This 'Double connection' has double advantages.

1. Strong resistance to lateral occlusal forces
2. No sinking of prosthetics
 - Most of internal connection shows 30~50 μ m of sinking following delivery of crown
 - S2 Option will not show sinking phenomenon, while maintaining the 5° internal connection

⑤ Adequate material for hygiene

Our KOLs recommend zirconia customized abutment and/or zirconia monolithic crown for the S2 molar implant.

Bioinert Bioaffinity

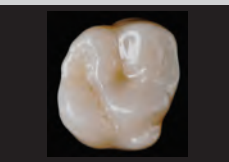

ZrGEN(Extra EZ (S2 Molar))

ZrGEN is the brand name of MegaGen Titanium Base. The strength of ZrGEN frees you from the chipping to conventional PFM prosthesis. Monolithic zirconia crowns have no metal substructure, **enhancing better survival rate!**

Bacterial Adhesion on Commercially Pure Titanium and Zirconium Oxide Disks: An In Vivo Human Study

Antonio Scarano, Maurizio Piattelli, Sergio Caputi, Gian Antonio Favero, and Adriano Piattelli JP 2004

The mucosal barrier at implant abutments of different materials

Maria Welander, Ingemar Abrahamsson, Tord Berglundh COIR19, 2008; 635-641

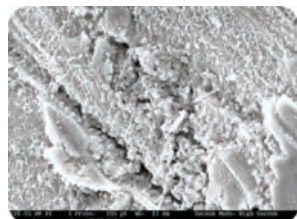

Titanium. A homogeneous layer of cocci or filamentous bacteria covers the titanium surface

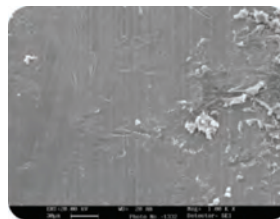

Zirconium oxide. A small number of bacteria cover the zirconium oxide surface.



(from left: Ti, ZrO₂, Ti, Au/Pt-alloy) in place 1 month after implant placement

- However, the Zirconia customized abutment has limitations on strength which leads fracture of zirconia and/or cement-break between ti-insert and Zirconia abutment.
- So MegaGen developed **new 'Ti-insert'** for the stronger customized abutment!

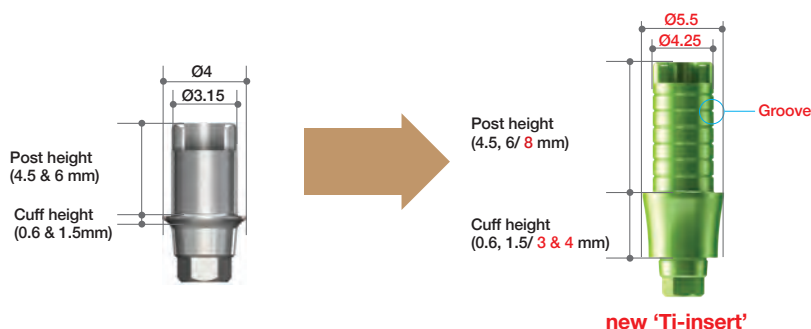

S2 Option with AnyRidge Clinical Case

➔ Clinical Case 1

- Courtesy of Dr. Seung Yeup Lee

S2 Option Line-up with AnyRidge implant can be the best solution in posterior zone

Fig 1. Initial Photo

Fig 2. Harvest Autogenous Bone

Fig 3. Implant placement

Fig 4. Provisionalization

Fig 5, 6. Before / After Surgery

Fig 7. Final Delivery

Fig 8. 6 yrs F/U

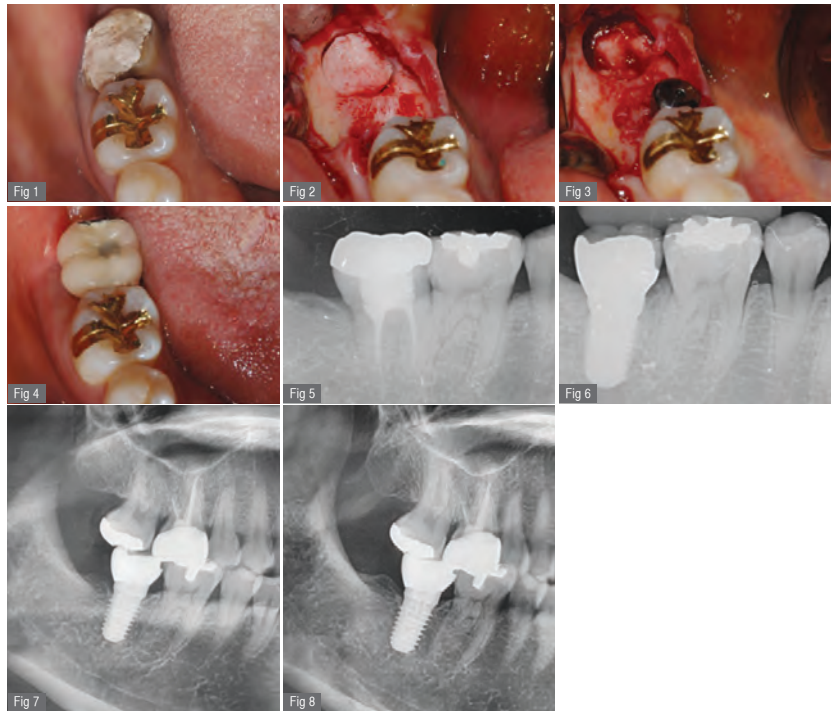

➔ Clinical Case 2

- Courtesy of Dr. Seung Yeup Lee

S2 Option Line-up with AnyRidge implant can be the best solution in posterior zone

Fig 1. Intra Oral before surgery

Fig 2. Panorama view

Fig 3. After Implant Placement

Fig 4. Connect Extra EZ (S2 Molar)-Post

Fig 5. Zirconia Customized Abutment using ZrGen

Fig 6, 7. Connect PMMA

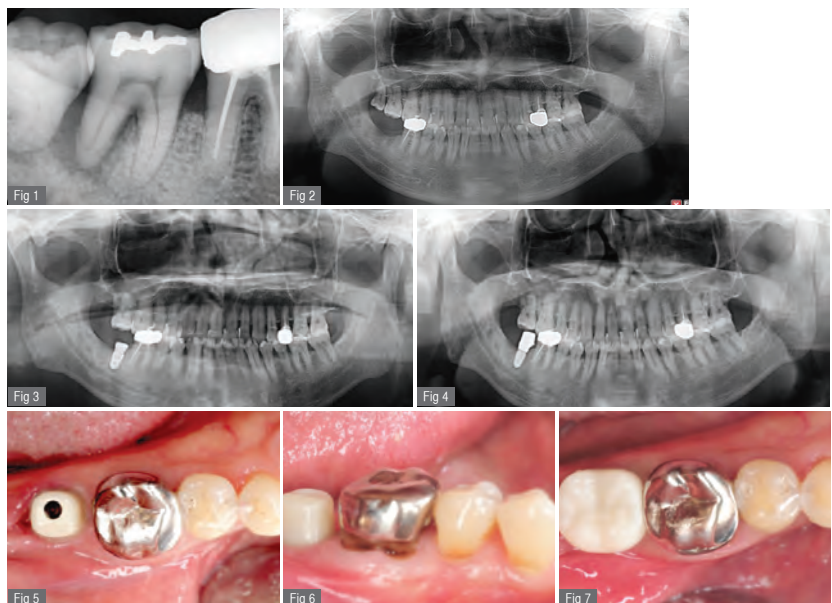

➔ Extra EZ (S2 Molar) Post Abutment

Extra EZ (S2 Molar) Post Abutment

- Multi Post Screw(AANMSF/AANMST) included.
- Useful when fixture is exposed over the gum line.
- Recommend torque : 35Ncm

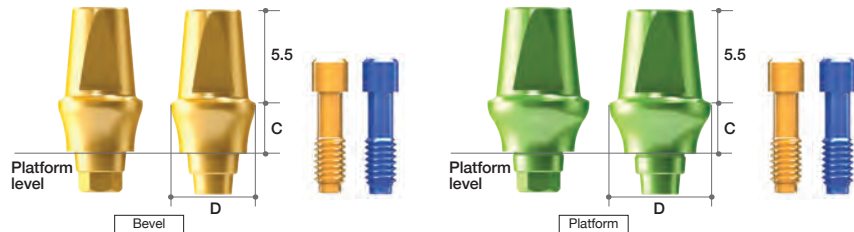

EZ Post Type

Core Diameter	Profile Diameter	Cuff	Type	Ref.C	
Ø3.3	Ø5.0	2	Hex	ARNEEH5025L	
		3		ARNEEH5035L	
		4		ARNEEH5045L	
		5		ARNEEH5055L	
		2		Non-Hex	ARNEEN5025L
	3	ARNEEN5035L			
	4	ARNEEN5045L			
	5	ARNEEN5055L			
	Ø6.0	Bevel	2	Hex	ARNEEH6025L
			3		ARNEEH6035L
			4		ARNEEH6045L
			5		ARNEEH6055L
			2		Non-Hex
		3	ARNEEN6035L		
4		ARNEEN6045L			
5		ARNEEN6055L			

Core Diameter	Profile Diameter	Cuff	Type	Ref.C	
Ø4.0	Ø6.0	2	Hex	ARREEH6025L	
		3		ARREEH6035L	
		4		ARREEH6045L	
		5		ARREEH6055L	
		2		Non-Hex	ARREEN6025L
	3	ARREEN6035L			
	4	ARREEN6045L			
	5	ARREEN6055L			
	Ø7.0	Platform	2	Hex	ARREEH7025L
			3		ARREEH7035L
			4		ARREEH7045L
			5		ARREEH7055L
			2		Non-Hex
		3	ARREEN7035L		
4		ARREEN7045L			
5		ARREEN7055L			

Milling Type

Core Diameter	Profile Diameter	Cuff Height	Post Height	Type	Ref.C
Ø3.3	Ø5.5	3	5.5	Bevel	AANEH3335L
Ø4.0	Ø5.5			Platform	AANEH4035L
Ø4.8	Ø6.5			Platform	AANEH4835L

- AANEH3335 used for fixture (Ø4.0~5.5)
- AANEH4035 used for fixture (Ø5.0, Ø5.5_Core ø4)
 - AANEH4035 is for the Core Diameter ø4.0mm (Fixture Diameter Ø5.0~5.5mm). It also can be used for Fixture Diameter Ø6.0~8.0mm for platform switching.
- AANEH4835 used for fixture (Ø6.0~8.0)
- Recommend torque : 35Ncm

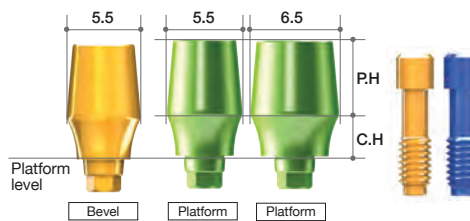

➔ Components for Extra EZ (S2 Molar) Post Abutment

Cover Screw

(Extra Type)

- Included in the fixture package.

- Use with a Hand Driver(1.2 Hex).
- Used for submerged type surgery.
- Protects the inner structure of a fixture.
- Different heights can be chosen according to the position of fixture below the crest.
- 1.6mm and 2.6mm height of Cover Screw can be purchased separately.
- Recommend torque : by hand (5 - 8Ncm)

Core Diameter	Profile Diameter	Type	Ref.C
Ø3.3	Ø4.0	Bevel	AANCSF4008
Ø4.0	Ø4.25	Platform	AANCSF4208

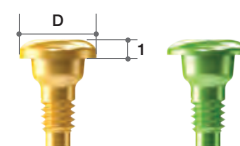

Extra Healing Abutment

- Use with a Hand Driver(1.2 Hex).
- Used for non-submerged type surgery or for two stage surgery.
- Choose appropriate diameter and height of Healing Abutment according to situation.
- Helps to form suitable emergence profile during period of gingival healing.
- Recommend torque : by hand (5 - 8Ncm)

Core Diameter	Profile Diameter	Height (mm)	Type	Ref.C		
Ø3.3	Ø5.0	3	Bevel	ARNEHA503		
		4		ARNEHA504		
		5		ARNEHA505		
		6		ARNEHA506		
		7		ARNEHA507		
		Ø6.0		Ø6.0	3	ARNEHA603
					4	ARNEHA604
5	ARNEHA605					
6	ARNEHA606					
Ø4.0	Ø4.2	3	Platform	ARREHA403		
		4		ARREHA404		
		5		ARREHA405		
		6		ARREHA406		
		7		ARREHA407		
		8		ARREHA408		
		9		ARREHA409		
	Ø6.0	Ø6.0	3	ARREHA603		
			4	ARREHA604		
			5	ARREHA605		
			6	ARREHA606		
	Ø7.0	Ø7.0	3	ARREHA703		
			4	ARREHA704		
			5	ARREHA705		
Ø4.8	Ø6.5	6	ARREHA706			
		7	ARREHA707			
		4	AANHAF484			

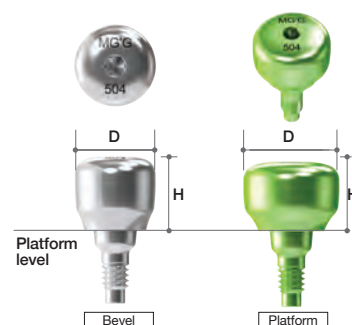

Lab Analog

- Blue : use Bevel type
- Yellow : use Platform type

Profile Diameter	Color	Ref.C
Ø4.0 ~ Ø5.5	Blue	AANLAF4055
Ø6.0 ~ Ø8.0	Yellow	AALLAF6080



➔ Components for Extra EZ Post (S2 Molar) Abutment

Impression Coping

(2-piece, Transfer Type)
(For Closed-tray Technique)

- Streamlined shape ; easy to transfer.
- Anti-rotation grooves match with hex structure of fixtures.
- Should be tightened with Impression Coping Driver (Page.374)
- Special impression coping screw which can be used with a 1.2mm hex driver is available on request.

Profile Diameter	Height (mm)	Type	Ref.C
Ø4.0	12	2-Piece	AANITH4012T
	16		AANITH4016T
Ø5.0	12		AANITH5012T
	16		AANITH5016T
Ø4.0	12	2-Piece Hand driver (1.2 Hex)	AANITH4012HT
	16		AANITH4016HT
Ø5.0	12		AANITH5012HT
	16		AANITH5016HT

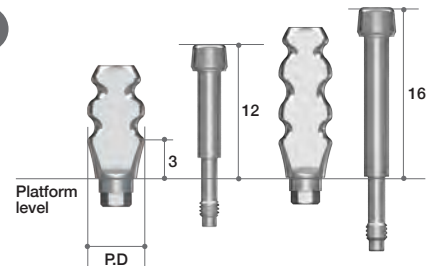

Impression Coping

(1-piece, Transfer Type)
(For Closed-tray Technique)

- Should be tightened with Impression Coping Driver (Page.374)
- Special impression coping screw which can be used with a 1.2mm hex driver is available on request.

Profile Diameter	Height (mm)	Type	Ref.C
Ø4.0	12	1-Piece	AANITN4012
	16		AANITN4016
Ø5.0	12		AANITN5012
	16		AANITN5016
Ø4.0	12	1-Piece Hand driver (1.2 Hex)	AANITN4012H
	16		AANITN4016H
Ø5.0	12		AANITN5012H
	16		AANITN5016H

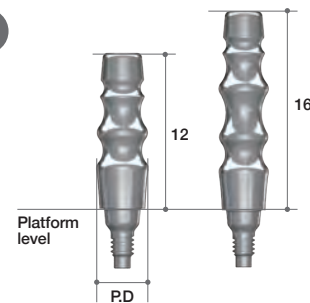

Impression Coping

(2-piece, Pick-up Type)
(For Open-tray Technique)

- Guide Pins : AANGPP0010 (7mm : Short) /
AANGPP0015 (12mm : Long) / AANGPP0020
(20mm : Extra-long)

- Square structure ; strong antirotation function.
- Designed for easy and accurate pick-up impression.
- Extra-long guide pin can be purchased separately.

Profile Diameter	Height (mm)	Type	Ref.C
Ø4.0	12	2-Piece	AANIPH4012T
	16		AANIPH4016T
	12		AANIPN4012T
	16		AANIPN4016T
Ø5.0	7		AANIPH5007T
	12		AANIPH5012T
	7		AANIPN5007T
	12		AANIPN5012T

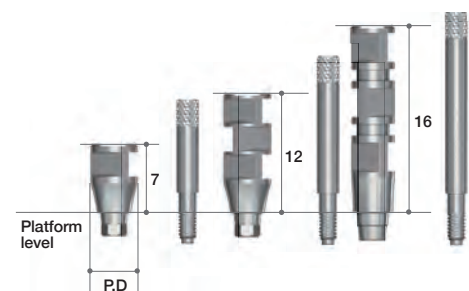

Temporary Abutment

(Titanium Extra Type)

- fixture package included.

- Use with a Hand Driver(1.2 Hex).
- Used for submerged type surgery.
- Protects the inner structure of a fixture.
- Different heights can be chosen according to the position of fixture below the crest.
- 1.6mm and 2.6mm height of Cover Screw can be purchased separately.
- Recommend torque : by hand (5 - 8Ncm)

Core Diameter	Profile Diameter	Type Mount	Connection	Ref.C
Ø3.3	Ø4.5	Bevel	Hex	ARNTAH4510T
			Non-Hex	ARNTAN4510T
Ø4.0	Ø4.75	Platform	Hex	ARRTAH4710T
			Non-Hex	ARRTAN4710T

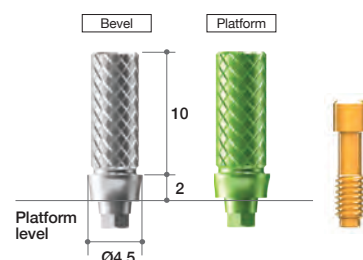

II. Abutment Level Prosthesis

1. Solid Abutment & Components

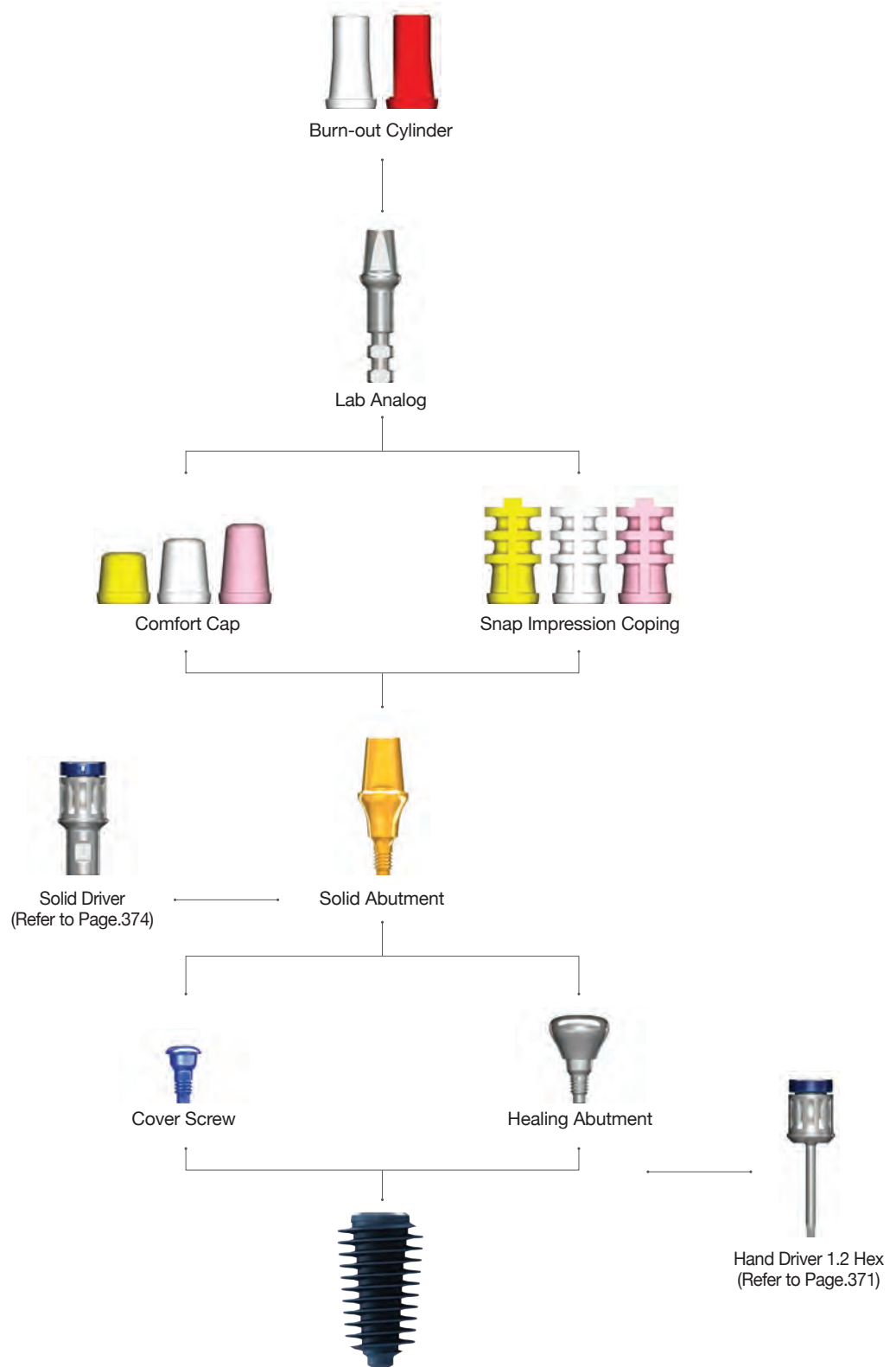

➔ Solid Abutment Option

Solid Abutment

- Used in cement retained restoration only.
- Solid Abutment should be placed into patient's mouth before taking impression.
- Onebody (screw + abutment)
- Should be tightened with a Solid Driver and a Torque Wrench : 35Ncm
- Four different profile diameters. (Ø4.0/5.0/6.0/7.0)
 - Should be tightened with special Solid Driver.
 - Wider profile has bigger post angulation. (4mm - 8°, 5mm - 10°, 6mm - 12°, 7mm - 14°)
- Four different cuff heights. (2/3/4/5mm)
- Three different post heights. (4/5.5/7mm)
- Recommend torque : 35Ncm

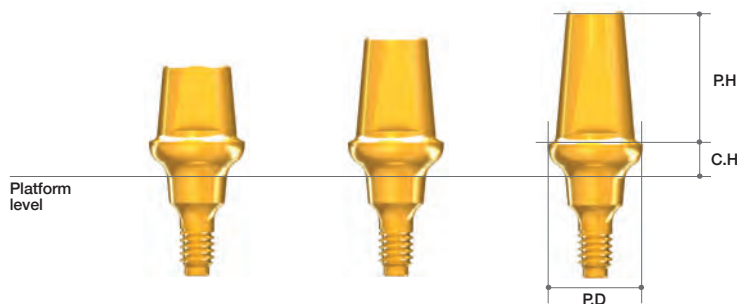

Profile Diameter	Cuff Height(mm)	Post Height(mm)	Ref.C	
Ø4.0	2	4	AANSAL4024	
	3		AANSAL4034	
	4		AANSAL4044	
	5		AANSAL4054	
	Ø4.0	2	5.5	AANSAL4025
		3		AANSAL4035
		4		AANSAL4045
		5		AANSAL4055
	Ø4.0	2	7	AANSAL4027
		3		AANSAL4037
		4		AANSAL4047
		5		AANSAL4057
Ø5.0	2	4	AANSAL5024	
	3		AANSAL5034	
	4		AANSAL5044	
	5		AANSAL5054	
	Ø5.0	2	5.5	AANSAL5025
		3		AANSAL5035
		4		AANSAL5045
		5		AANSAL5055
	Ø5.0	2	7	AANSAL5027
		3		AANSAL5037
		4		AANSAL5047
		5		AANSAL5057
Ø6.0	2	4	AANSAL6024	
	3		AANSAL6034	
	4		AANSAL6044	
	5		AANSAL6054	
	Ø6.0	2	5.5	AANSAL6025
		3		AANSAL6035
		4		AANSAL6045
		5		AANSAL6055
	Ø6.0	2	7	AANSAL6027
		3		AANSAL6037
		4		AANSAL6047
		5		AANSAL6057
Ø7.0	2	4	AANSAL7024	
	3		AANSAL7034	
	4		AANSAL7044	
	5		AANSAL7054	
	Ø7.0	2	5.5	AANSAL7025
		3		AANSAL7035
		4		AANSAL7045
		5		AANSAL7055
	Ø7.0	2	7	AANSAL7027
		3		AANSAL7037
		4		AANSAL7047
		5		AANSAL7057

➔ Components for Solid Abutment

Snap Impression Coping

- For impression on Solid Abutments.
- 3 colors for different post heights.
- 4 different diameters for profile diameters. (Ø4, 5, 6, 7)
- Do not use when abutment is trimmed.

Profile Diameter	Ref.C
Ø4.0	AANSIF440
	AANSIF455
	AANSIF470
Ø5.0	AANSIF540
	AANSIF555
	AANSIF570
Ø6.0	AANSIF640
	AANSIF655
	AANSIF670
Ø7.0	AANSIF740
	AANSIF755
	AANSIF770

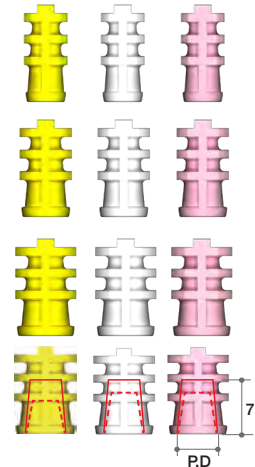

Comfort Cap

- Protects the Solid Abutment and minimizes irritation to tongue and oral mucosa.
- Can be applied under temporary prosthetics.
- Color coded according to post heights.

Profile Diameter	Post Height(mm)	Ref.C
Ø4.0	4	AANCCF440
	5.5	AANCCF455
	7	AANCCF470
Ø5.0	4	AANCCF540
	5.5	AANCCF555
	7	AANCCF570
Ø6.0	4	AANCCF640
	5.5	AANCCF655
	7	AANCCF670
Ø7.0	4	AANCCF740
	5.5	AANCCF755
	7	AANCCF770

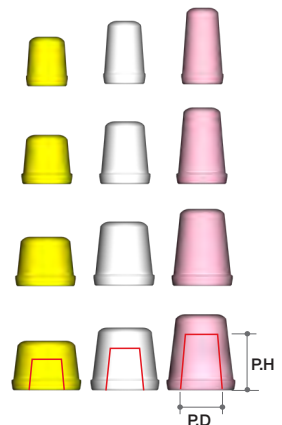

Lab Analog

- Directly connected to the Snap Impression Coping in the impression to make a stone model.

Profile Diameter	Height(mm)	Ref.C
Ø4.0	4	AANSLF440
	5.5	AANSLF455
	7	AANSLF470
Ø5.0	4	AANSLF540
	5.5	AANSLF555
	7	AANSLF570
Ø6.0	4	AANSLF640
	5.5	AANSLF655
	7	AANSLF670
Ø7.0	4	AANSLF740
	5.5	AANSLF755
	7	AANSLF770

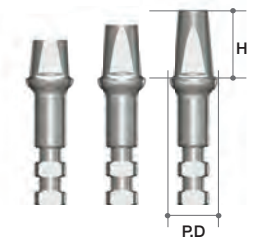

Burn-out Cylinder

- Fits with a Lab Analog(solid level).
- Easy to wax-up and accurate casting.
- White Cylinder for multiple unit.
- Red Cylinder for single crown.

Profile Diameter	Type	Ref.C
Ø4.0	Multiple	AANBCB470
Ø5.0		AANBCB570
Ø6.0		AANBCB670
Ø7.0		AANBCB770
Ø4.0	Single	AANBCS470
Ø5.0		AANBCS570
Ø6.0		AANBCS670
Ø7.0		AANBCS770

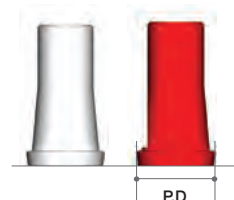

II. Abutment Level Prosthesis

2. Octa Abutment & Components

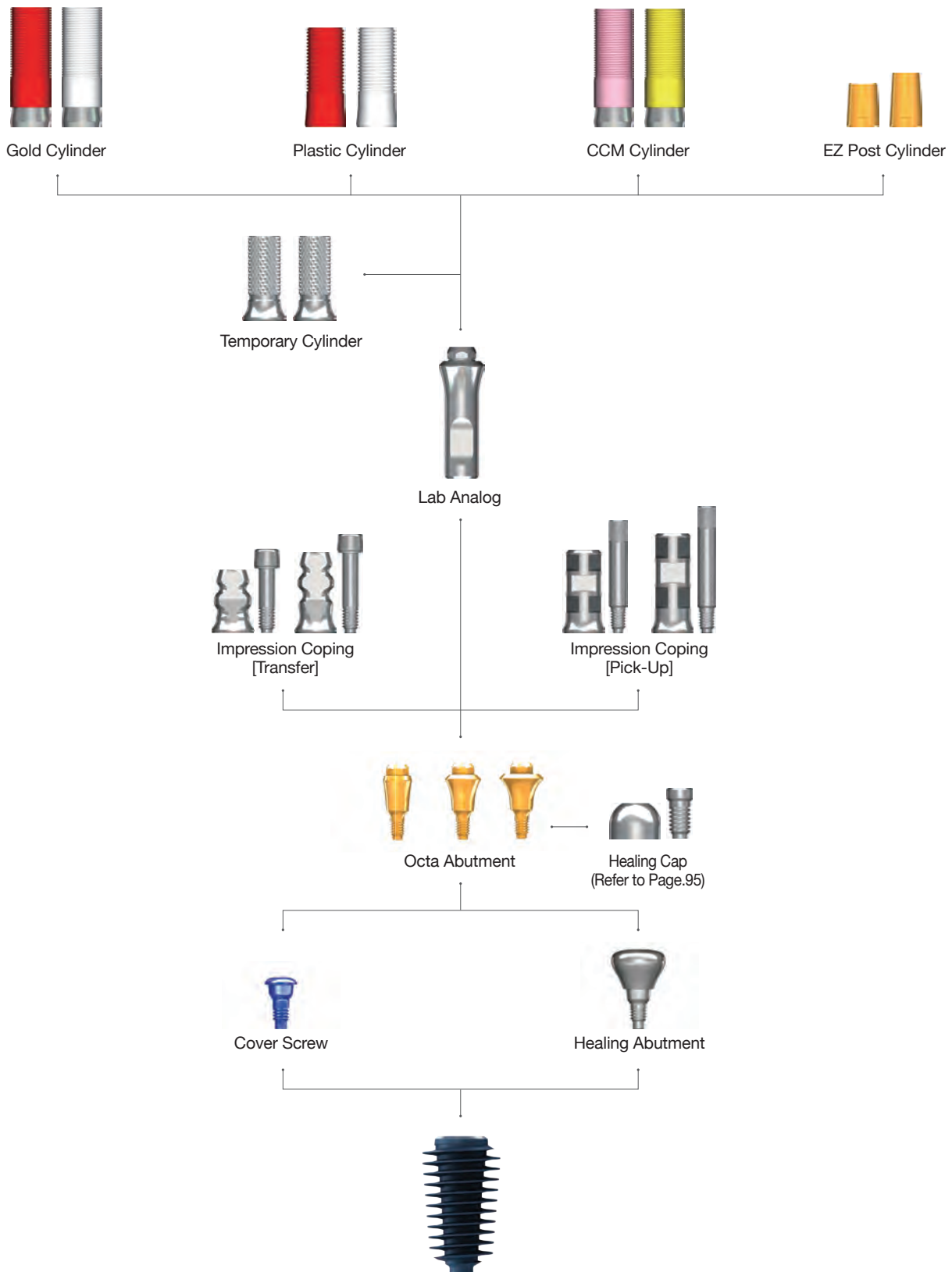

➔ Components for Octa Abutment (Continued)

Octa Abutment

- Used in manufacturing multiple screw-retained prosthetics.
- Recommend torque : 35Ncm

Profile Diameter	Cuff Height (mm)	Ref.C
Ø4.0	1	AANOAF4010
	2	AANOAF4020
	3	AANOAF4030
	4	AANOAF4040
	5	AANOAF4050
Ø5.0	1	AANOAF0010
	2	AANOAF0020
	3	AANOAF0030
	4	AANOAF0040
	5	AANOAF0050
Ø6.0	1	AANOAF6010
	2	AANOAF6020
	3	AANOAF6030
	4	AANOAF6040
	5	AANOAF6050

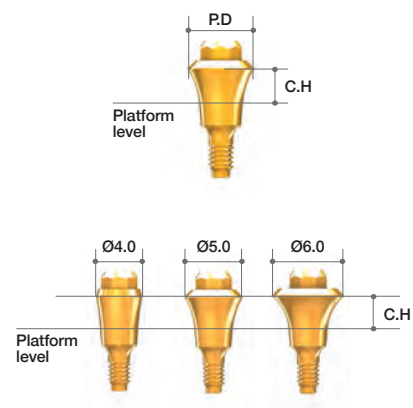

Healing Cap

- Cylinder Screw(IRCS200) included.
- Protects Octa Abutment and minimizes irritation to tongue and oral mucosa.

Profile Diameter	Ref.C
Ø4.0	AANOHC4000T
Ø5.0	IHC400T
Ø6.0	AANOHC6000T



Impression Coping

(Transfer)

- Guide Pin(AAOTGP10 / AAOTGP12) included.
- Should be tightened with Impression Coping Driver (Page.374)
- Special impression coping screw which can be used with a 1.2mm hex driver is available on request.

Profile Diameter	Height (mm)	Type	Ref.C
Ø4.0	7.5	Octa	AAOITO4010T
		Non-Octa	AAOITN4010T
	9.5	Octa	AAOITO4012T
		Non-Octa	AAOITN4012T
Ø5.0	7.5	Octa	AAOITO5010T
		Non-Octa	AAOITN5010T
	9.5	Octa	AAOITO5012T
		Non-Octa	AAOITN5012T
Ø6.0	7.5	Octa	AAOITO6010T
		Non-Octa	AAOITN6010T
	9.5	Octa	AAOITO6012T
		Non-Octa	AAOITN6012T

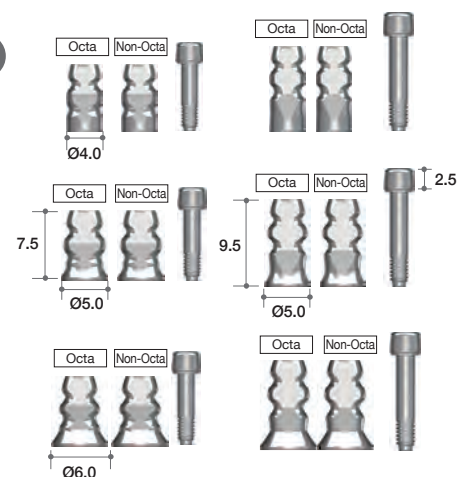

➔ Components for Octa Abutment

Impression Coping (Pick-Up)

- Guide Pin(AAOPGP10 / AAOPGP12) included.

Profile Diameter	Height (mm)	Type	Ref.C
Ø4.0	10.0	Octa	AAOIPO4010T
		Non-Octa	AAOIPN4010T
	12.0	Octa	AAOIPO4012T
		Non-Octa	AAOIPN4012T
Ø5.0	10.0	Octa	AAOIPO5010T
		Non-Octa	AAOIPN5010T
	12.0	Octa	AAOIPO5012T
		Non-Octa	AAOIPN5012T
Ø6.0	10.0	Octa	AAOIPO6010T
		Non-Octa	AAOIPN6010T
	12.0	Octa	AAOIPO6012T
		Non-Octa	AAOIPN6012T

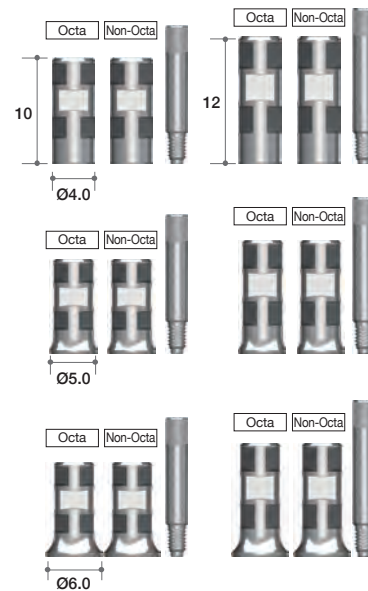

Lab Analog

Profile Diameter	Ref.C
Ø3.8	AANOLA4000
Ø4.8	IOA300
Ø5.8	AANOLA6000

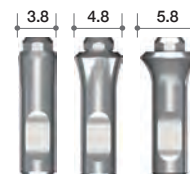

Temporary Cylinder

- Cylinder Screw(IRCS200) included.

• Recommend torque : 25Ncm

Profile Diameter	Type	Ref.C
Ø4.0	Octa	AANOTCO4010T
	Non-Octa	AANOTCN4010T
Ø5.0	Octa	AANOTCO5010T
	Non-Octa	AANOTCN5010T
Ø6.0	Octa	AANOTCO6010T
	Non-Octa	AANOTCN6010T

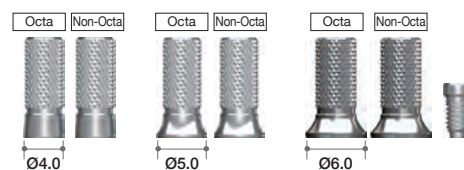

EZ Post Cylinder

- Cylinder Screw(IRCS200) included.

- Recommend torque : 35Ncm

Profile Diameter	Post Height(mm)	Type	Ref.C
Ø4.0	5.5	Octa	AAOECO4005T
	7.0		AAOECO4007T
	5.5	Non-Octa	AAOECN4005T
	7.0		AAOECN4007T
Ø5.0	5.5	Octa	AAOECO5005T
	7.0		AAOECO5007T
	5.5	Non-Octa	AAOECN5005T
	7.0		AAOECN5007T
Ø6.0	5.5	Octa	AAOECO6005T
	7.0		AAOECO6007T
	5.5	Non-Octa	AAOECN6005T
	7.0		AAOECN6007T

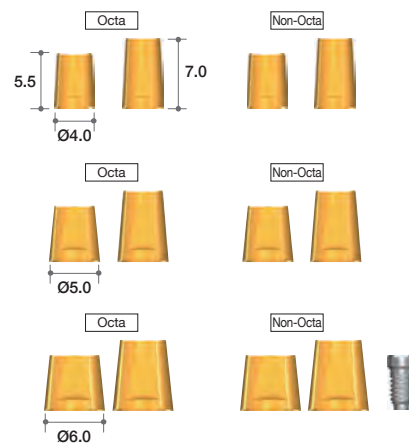

Gold Cylinder

- Cylinder Screw(IRCS200) included.

- For customizing abutment for screw retained multi-unit restoration.
- Available in both octa(red) and non-octa(white).
- Melting point of gold alloy : 1063°C
- Threaded sleeves allow better retention of resin or wax.
- Available in three diameters (Ø4.0, 5.0, 6.0).
- Recommend torque : 30Ncm

Profile Diameter	Type	Ref.C
Ø4.0	Octa	AANGCO4000T
	Non-Octa	AANGCN4000T
Ø5.0	Octa	IOGO100T
	Non-Octa	IIGN100T
Ø6.0	Octa	AANGCO6000T
	Non-Octa	AANGCN6000T

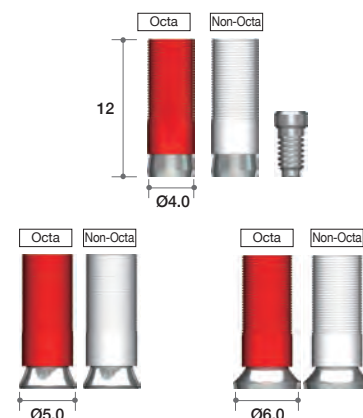

➔ Components for Octa Abutment

CCM Cylinder

- Cylinder Screw(IRCS200) included.

- Threaded sleeves allow a better retention of resin or wax.
- Available in both octa (pink) and non-octa (yellow) and three diameters (Ø4.0, 5.0, 6.0).
- Recommend torque : 35Ncm
- Melting temperature of CCM : 1300~1400°C
- Can be casted with non-precious alloys (Ni-Cr, Cr-Co alloys).

Profile Diameter	Type	Ref.C
Ø4.0	Octa	AANCCO4000T
	Non-Octa	AANCCN4000T
Ø5.0	Octa	AANCCO5000T
	Non-Octa	AANCCN5000T
Ø6.0	Octa	AANCCO6000T
	Non-Octa	AANCCN6000T

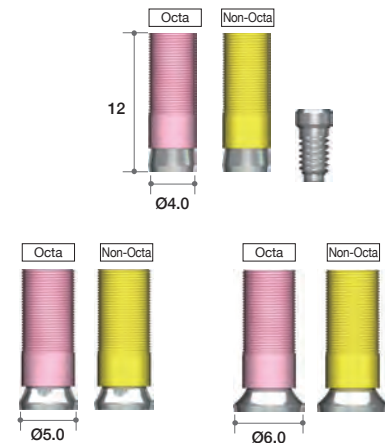

Plastic Cylinder

- Cylinder Screw(IRCS200) included.

- Economical option.
- Used for customizing abutment a screw retained multi-unit restorations.
- Available in both octa (red) and non-octa (white)
- Threaded sleeves allow a better retention of resin or wax.
- Recommend torque : 25Ncm

Profile Diameter	Type	Ref.C
Ø4.0	Octa	AAOTCO4010T
	Non-Octa	AAOTCN4010T
Ø5.0	Octa	IOPH100T
	Non-Octa	IOPN100T
Ø6.0	Octa	AAOTCO6010T
	Non-Octa	AAOTCN6010T

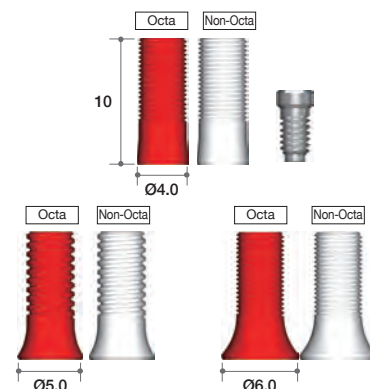

II. Abutment Level Prosthesis

3-1. Multi-unit Abutment & Components (All-on-4) (N_Type)

For the design concept and rationale of the Multi-unit Abutment, Please refer to page.100

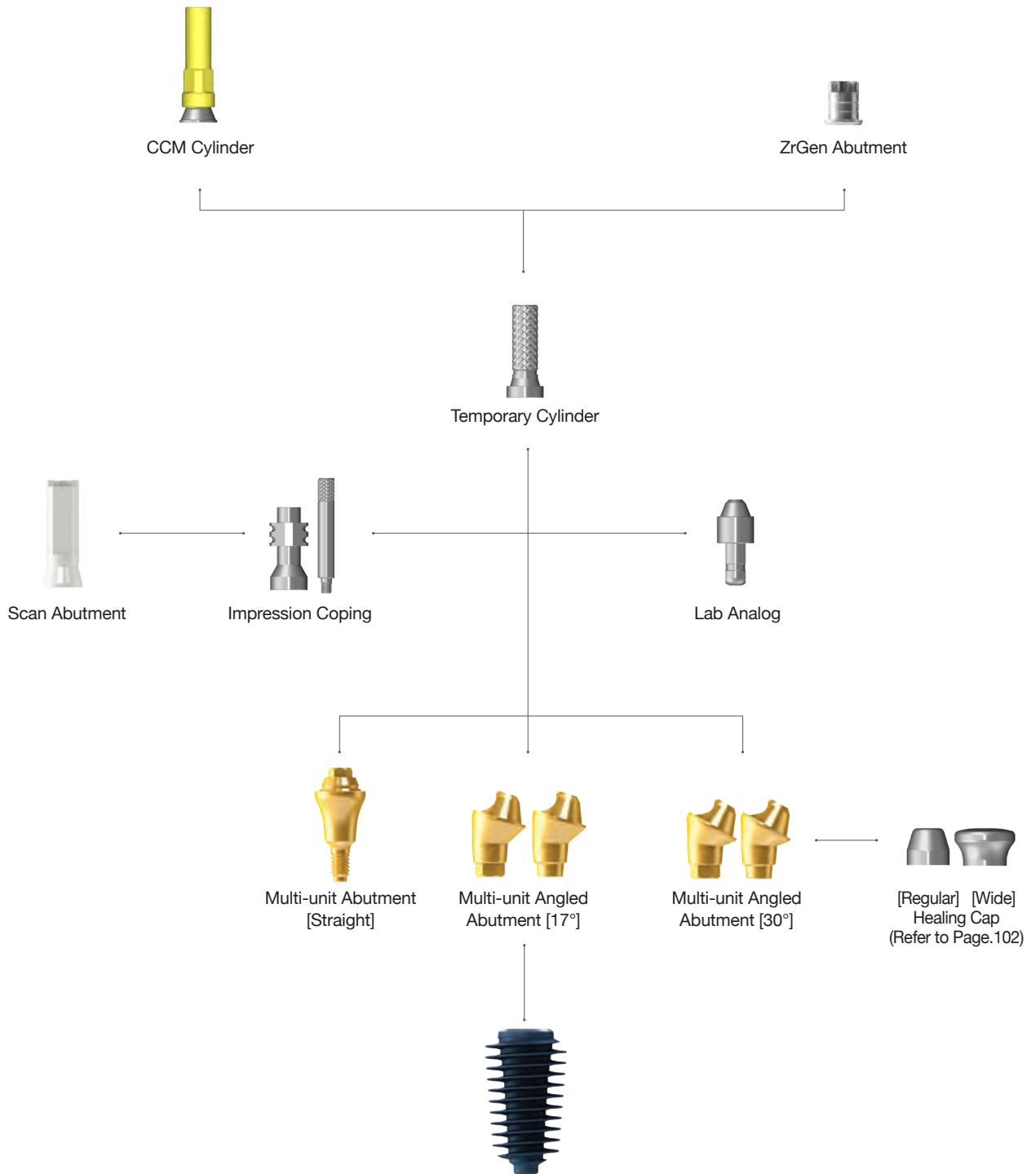

►► Multi-unit Abutment™

Multi-unit Abutment Design Concept

MegaGen Implant develops the special abutment named as Multi-unit Abutment, which can be the solution for the edentulous patients. With 4 fixtures placed into patient's ridge and a hybrid denture on those four fixtures, a patient can recover his or her dental condition almost completely. In most cases, Multi-unit Abutments work in a set of 2 x straight type abutment for anterior position and 2 x angled type abutment on posterior position.

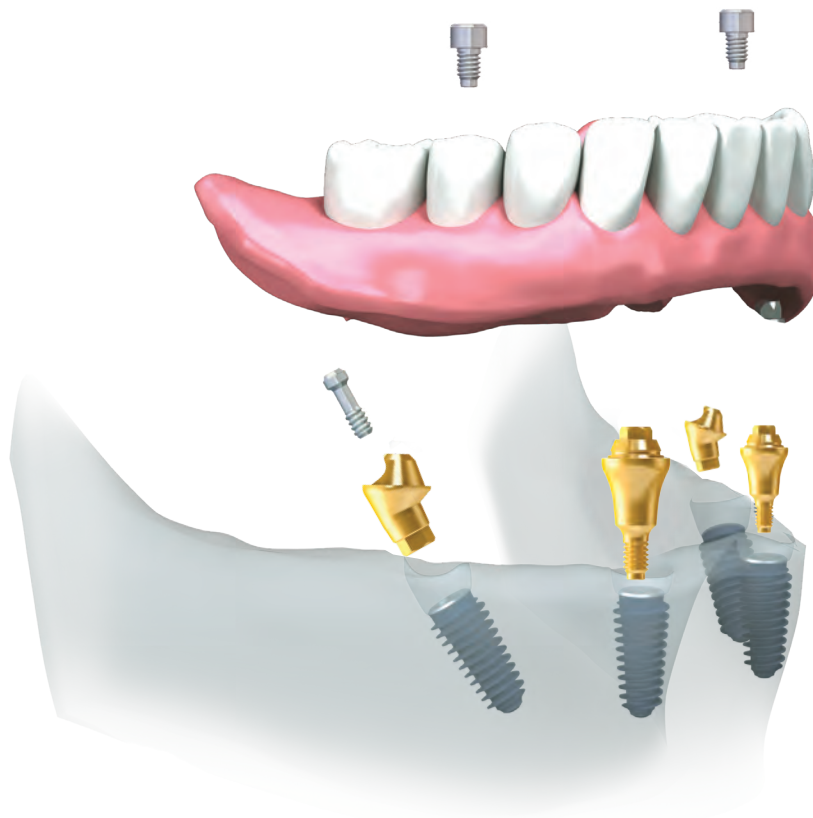

Features

You could see how Multi-unit Abutment functions and what benefits you could get from Multi-unit Abutment are as the followings:

- 2 fixtures which are slantly implanted on posterior position are osseointegrated with cancellous bone. These fixtures function as dispersing vertical load on alveolar bone.
- Multi-unit Abutment is only 4 fixtures + 4 abutments. It means that dental surgeon has enough places for surgery. Therefore, it will be easy to find and place 4 fixtures into ridge where abundant cancellous bone exists.
- A doctor can use graft bone material if a patient doesn't have enough alveolar bone. However, the slantly placed fixtures can overcome the patient's insufficient bone by getting good holding strength with this angulation.
- In addition, these angulated fixtures can avoid touching important anatomies, such as mandibular nerve and maxillary sinus.
- All on 4 technique is also possible to do guided surgery using R2GATE Guide with a diagnosis from R2GATE.

►► Multi-unit Abutment N Type

The solution for the edentulous patients

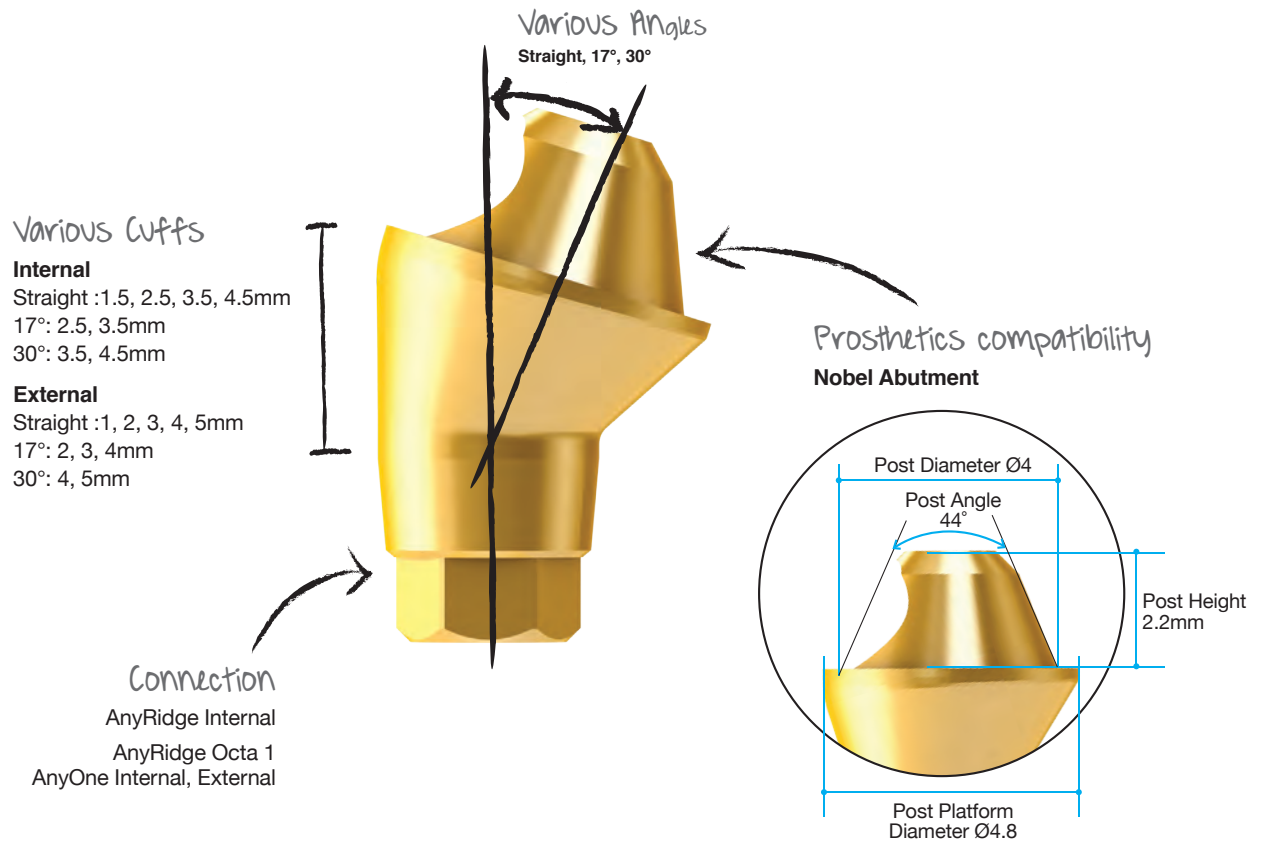

Benefit

1. Easy and economical treatment solution for compromised edentulous cases.
2. Expensive and time consuming bone graft may not be necessary.
3. Multiple angles (0°, 17°, 30°) support different implant insertion paths.
4. Universally compatible with other Multi-unit systems.

Available implant System

- AnyRidge Internal
- AnyRidge Octa 1
- AnyOne Internal
- AnyOne External

Compatibility with others' Multi-unit level prosthetic components

- ✓ Post Height
- ✓ Post Diameter
- ✓ Post Angle
- ✓ Abutment Angle
- ✓ Cuff Height

➔ Multi-unit Abutment

Multi-unit Abutment [AR] - Straight

- MUA Straight Carrier (MUASC) included
- Recommend torque : 35Ncm

Cuff Height (mm)	Type	Ref.C
1.5	1-piece (M1.8)	MUAARN0015C
2.5		MUAARN0025C
3.5		MUAARN0035C
4.5		MUAARN0045C

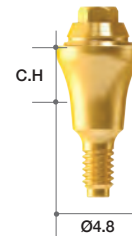

Multi-unit Angled Abutment [AR] - 17°

- MUA Screw (MUAARS) included
- MUA Angled Carrier (MUAAC) included
- Recommend torque : 25Ncm

Cuff Height (mm)	Type	Ref.C
2.5	Hex	MUAARH1725LC
3.5		MUAARH1735LC
4.5		MUAARH1745LC
2.5	Non-Hex	MUAARN1725LC
3.5		MUAARN1735LC
4.5		MUAARN1745LC



Multi-unit Angled Abutment [AR] - 30°

- MUA Screw (MUAARS) included
- MUA Angled Carrier (MUAAC) included
- Recommend torque : 25Ncm

Cuff Height (mm)	Type	Ref.C
3.5	Hex	MUAARH3035LC
4.5		MUAARH3045LC
3.5	Non-Hex	MUAARN3035LC
4.5		MUAARN3045LC

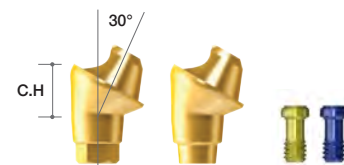

➔ Components for Multi-unit Abutment (Continued)

Impression coping (Pick-up)

- Guide pin (MUAGP) included
- Use to take an impression at the abutment level.
- Open tray method.

Connection	Ref.C
Non-Hex	MUAICT

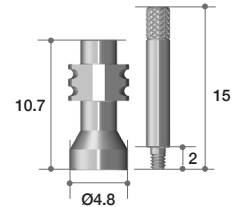

Lab Analog

- Use to duplicate the Multi-unit abutment in the working model.
- Available to use as a RP Analog for 3D printed working model.

Head form	Ref.C
Multi-unit Abutment(Nobel)	MUALA

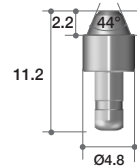

Temporary Cylinder

- Cylinder Screw (MUAS) included
- Use for fabricating acrylic provisional restoration.
- Grooves on the post cylinder allow storing resin adhesion.
- Back-up screw is included.
- Recommend torque : 15Ncm

Connection	Ref.C
Non-Hex	MUATCL

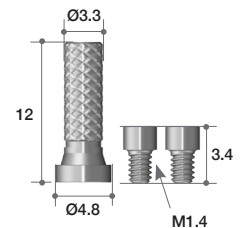

CCM Cylinder

- Cylinder Screw (MUAS) 2EA included
- Use for fabricating screw retained prostheses with metal reinforced or bar structured overdentures.
- Available to cast with non-precious dental alloys (Ni-Cr, Cr-Co alloys)
- Melting temperature of CCM base: 1300~1400°C
- Back-up screw is included.
- Recommend torque : 15Ncm

Connection	Ref.C
Non-Hex	MUACCML

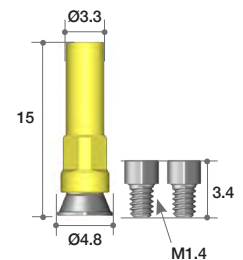

➔ Components for Multi-unit Abutment

Healing Cap

- Cylinder Screw (MUAS) 2ea included
- The size of healing cap can be selected depending on soft tissue volume or type of restorations.

Type	Ref.C
Regular	MUAHCL
Wide	MUAHCWL

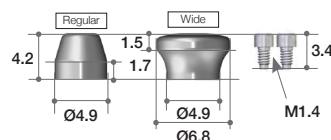

Healing Cap Set reference code

Order code : Add "P" after the existing reference code

Ex) MUAHCL → MUAHCP



Try-in Abutment

- Cuff height is indicated with laser markings
- Straight 17°, 30°
- Non-hex type

Angle	Cuff Marking	Ref.C
Straight	1.5 / 2.5 / 3.5 / 4.5	MUTIAAR00C
17°	2.5 / 3.5 / 4.5	MUTIAAR17C
30°	3.5 / 4.5	MUTIAAR30C

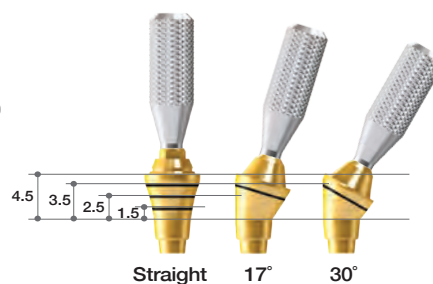

Try-in Abutment Set reference code

Order code : MUTIAAR00CP



- * Available Systems : AnyRidge, AnyRidge Octa 1, AnyOne Internal, AnyOne External
- * Kit contains Straight, 17° and 30° type of Try-in Abutments (1 each)



Multi-unit Driver

- Use to torque straight type Multi-unit Abutments.
- Use with a torque wrench (ref code: **MTW300A**)

Hex	Length	Ref.C
2.0	10	MUD10

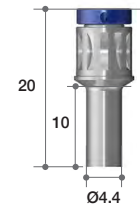

Right Angle Driver

- Use to torque straight type Multi-unit Abutments.
- Use with latch-type handpiece.
- Use with Meg-TORQ (ref code: **MEG_TORQ**)

Hex	Length	Ref.C
2.0	10	MURAD10

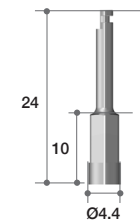

Hand Driver

- Use for abutment screw with 1.2 hex hole.
- Use up to 15° divergent.
- It should use under 30Ncm torque.

Hex	Length	Ref.C
1.2	20	MUHD1220

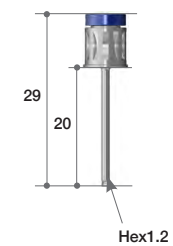

Removal Driver

- Use for abutment screw with 1.2 hex hole.
- Use up to 15° divergent.
- Exclusively for AnyRidge system.
- It should use under 30Ncm torque.

Hex	Length	Ref.C
1.2	20	MUARD20

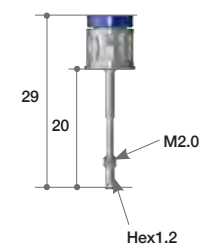

►► Screw & Abutment Tightening Torque Guide

- Abutment Screw (M1.8 & M2.0) : 25Ncm
- Cylinder Screw (M1.4) : 15Ncm
- Straight Abutment (M1.8 & M2.0) : 35Ncm

Instruction for removing abutment screw from Multi-unit abutment [Exclusively for AnyRidge system]

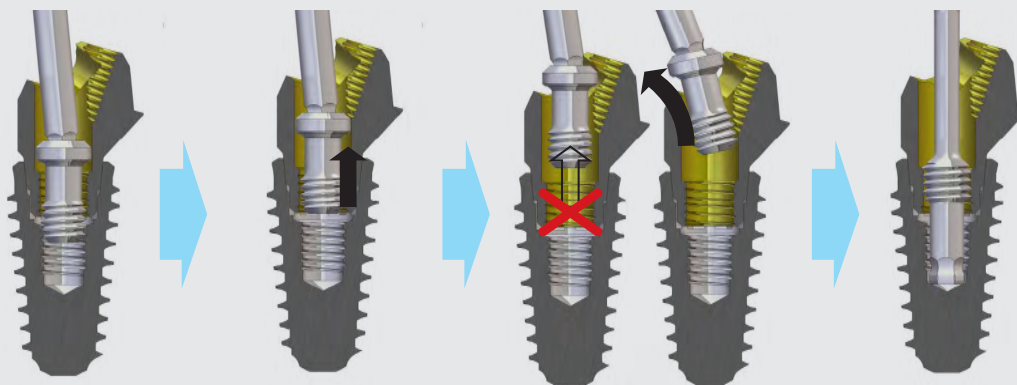

1. Completely unscrew abutment screw by rotating it counterclock wise (approximately 4 rotations are required). It should sue with a Hand Driver (ref code: MUHD1220)
2. Pull the Hand Driver up straight until it is visible through abutment crew hole. Shaking left and right may be required if the screw becomes stuck inside of the abutment hole.
3. Slightly rotate the screw to the main access hole. Otherwise the screw could fall back into the screw hole due to disturbance of abutment structure.
4. Remove abutment with the Removal Driver (ref code: MUARD20) by rotating it clockwise.

Driver Tightening Torque Guide

1. Multi-unit Abutment Remover Driver



2. Multi-unit Hand Driver



- Excessive torque more than 30Ncm may cause fracturing of the driver.
- Straight type Multi-unit abutment needs to use the Multi-unit Driver that is provided in the starting package. (ref code: MUD10)
- **Strongly recommended to pick up the abutment screw by pressing the Hand Driver to remove the abutment screw from the Multi-unit abutment.**

➔ Components for Multi-unit Abutment

Surgical Guide

- The distance between the lines is 7mm
- Put center pin after initial drilling at the centric of arch. (Refer to the surgical protocol on page.110)

Angle	Marking Length (mm)	Ref.C
30°	7	MUSG70

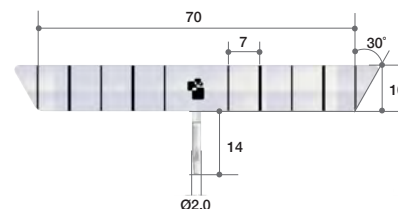

▶▶ How to use Surgical Guide

- ※ As Canine and second premolar are most commonly used, the surgical guide has thicker lines for easier identification.
- ※ The surgical guide is able to use for first molar depending on surgical plan.

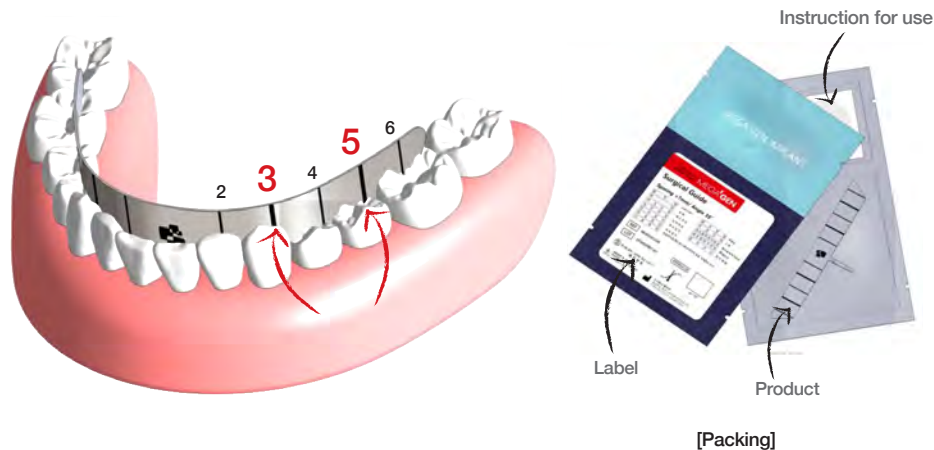
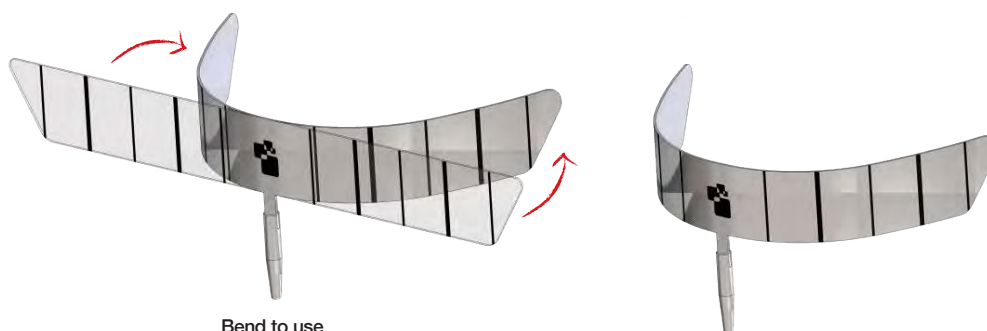

►► Multi-unit Abutment Set Contents

Multi-unit Abutment Healing cap type Set reference code

Order code : Add "HP" after the existing reference code

Ex) MUAARH1725LC → MUAARH1725 **HP**

Multi-unit Abutment CCM type Set reference code

Order code : Add "P" after the existing reference code

Ex) MUAARH1725LC → MUAARH1725 **P**

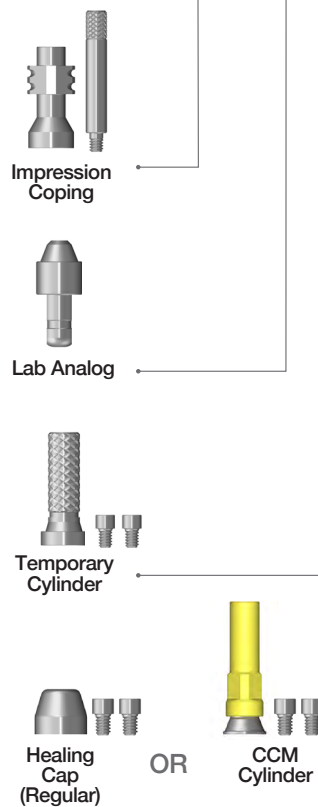

▶▶ Starting Package Contents



	Type	Ref.C
Healing Cap	Hex	SKARHN3000H
	Non Hex	SKARNN3000H
CCM Abutment	Hex	SKARHN3000
	Non Hex	SKARNN3000

Straight 8set (2set x 4kind of cuff)	Angle 17° 6set (2set x 3kind of cuff)	Angle 30° 4set (2set x 2kind of cuff)
<p>Multi-unit Abutment with *carrier * MUA carrier is used to pick-up an abutment to the patient's mouth, and check its insertion angle.</p> <p>Healing Cap (Regular) or CCM Cylinder Temporary Cylinder Lap Analog Impression Coping</p>		

Surgical Instrument

Multi-unit Driver Right Angle Driver Hand Driver Removal Driver

Healing Cap 2set

Regular
Wide

Try-in Abutment 1set (Straight, 17°, 30° each 1ea)

Surgical Guide 2ea

►► Surgical Protocol

Conventional Surgery

1. Initial drilling

For placement of center pin after initial drilling in the centric of the arch. The drilling hole should be in lingual area of the arch to ensure the best result.

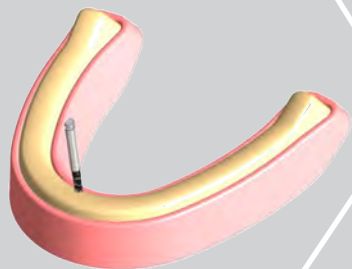

2. Guide Bending & Position

Bend according to the patient's arch.

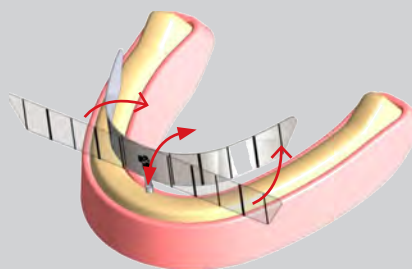

7. Tightening the Abutment

Abutment Screw tightening Torque : 25Ncm

After connecting Abutment Screw, remove Carrier from Abutment. For 17° abutment, you need to tighten it by tilting Driver about 5°. Connect Abutment and check the path using Carrier.

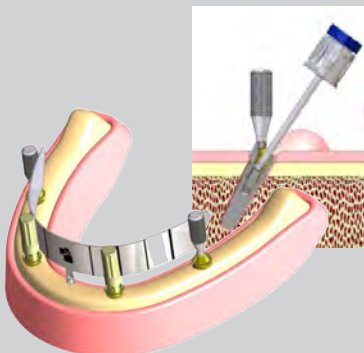

Straight Abutment tightening Torque : 35Ncm

After removing Carrier, connect Abutment to the Fixture using Right Angle Driver or MUA Driver.

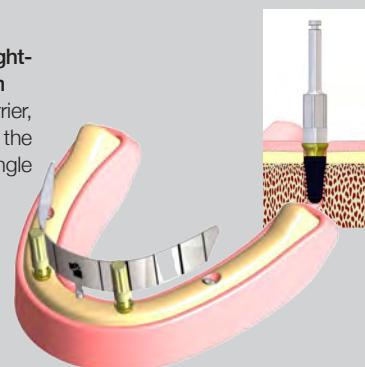

8. Impression

Take an impression with an individual tray. (Open tray method is strongly recommended to avoid any error in the future.)

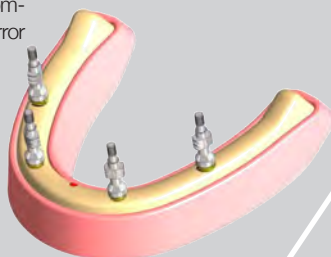

9. Healing Cap

Cylinder Screw tightening Torque : 15Ncm

Place Healing Cap on top of Multi-unit abutment, and connect Cylinder Screw with the Hand Driver.

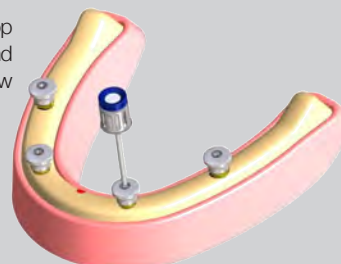

3. Drilling

Drill according to the surgical plan.

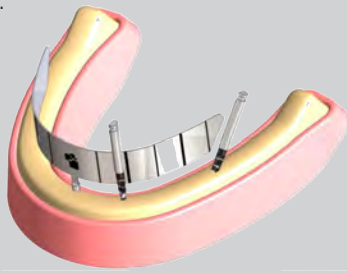

4. The fixture is implanted

Place implant fixtures according to the surgical plan and do not exceed torque value (60Ncm)

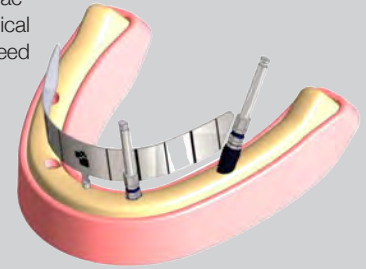

6. Abutment Selection

Select the appropriate set after checking the angulation and cuff height that were measured with the Try-in abutment. Connect the abutment onto the fixture and check the angulation and the cuff height.



5. Try-in Abutment

Using the laser marking on the Try-in abutment, select the appropriate cuff height and angulation of Multi-unit abutments.

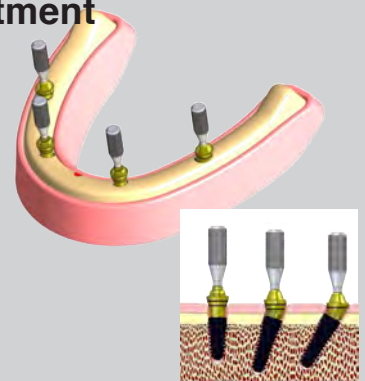

10. Suture

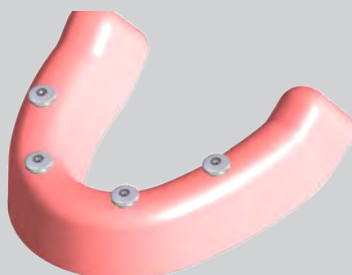

► Surgical Protocol Guided Surgery

1. Guide

Place a R2GATE Guide.

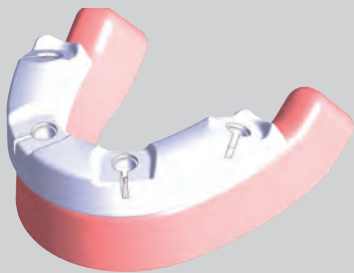

2. Narrow Crest Drill

For the cases with narrow ridge or placing a fixture slanted on the lingual side, you can flatten the surface and drill stably without slipping

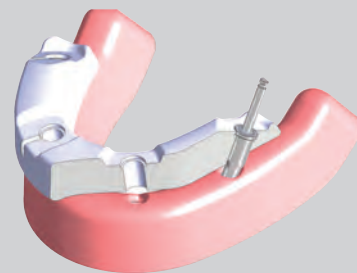

8. Setting Temporary and Denture

Reline the temporary denture with resin to fill the space around the Temporary Cylinder.



7. Connect Temporary Cylinder in the front

Connect the Temporary Cylinders in the front. Make sure that holes in the denture are free from any contact with the Temporary Cylinder. Adjust the holes until there is no contact between the denture and the Temporary Cylinder.
*If the Temporary Cylinder is fixed using Guide Pin, resin flow into access hole will be prevented.

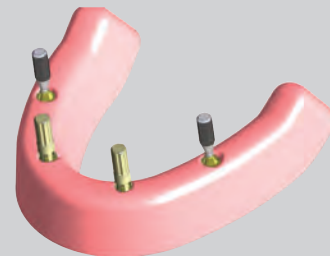

9. Connect Temporary Cylinder in the back

Connect rest of the Temporary Cylinders in the back, make sure that the holes in the denture are free from any contact with the Temporary Cylinder. Adjust the holes until there is no contact between the denture and the Temporary Cylinder.

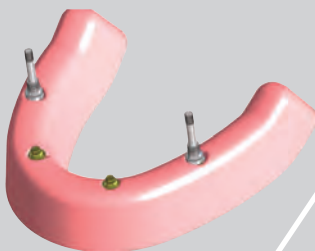

10. Setting Temporary and Denture

All temporary cylinders are picked up in the denture with resin.

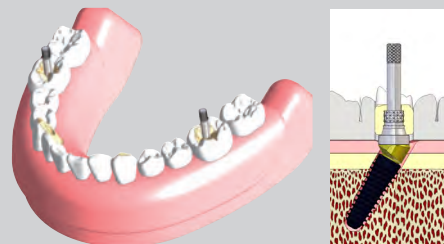

3. Drilling

Drill according to the drilling sequence.



4. Fixture Placement



6. Abutment Selection

Select the appropriate set after checking the angulation and cuff height that were measured with the Try-in abutment. Connect the abutment onto the fixture and check the angulation and the cuff height.



5. Try-in Abutment

Using the laser marking on the Try-in abutment, select the appropriate cuff height and angulation of Multi-unit abutments.

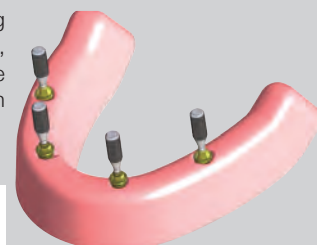
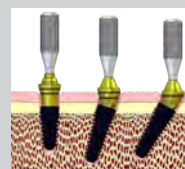

11. Temporary Fixation

Remove Denture and fill up the bottom and other non-resin filled parts with resin and completely fix Temporary Cylinder.



12. Tighten the Denture

Cylinder Screw tightening Torque : 15Ncm
Set Denture onto Multi-unit Abutment and tighten cylinder

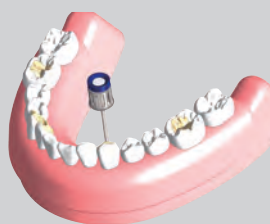

13. Finish

Close Hole using EZ Seal and finalize the surgery.



►► Multi-unit Abutment S Type

The solution for the edentulous patients

For the design concept and variable of the Multi-unit Abutment, Please refer to page.100

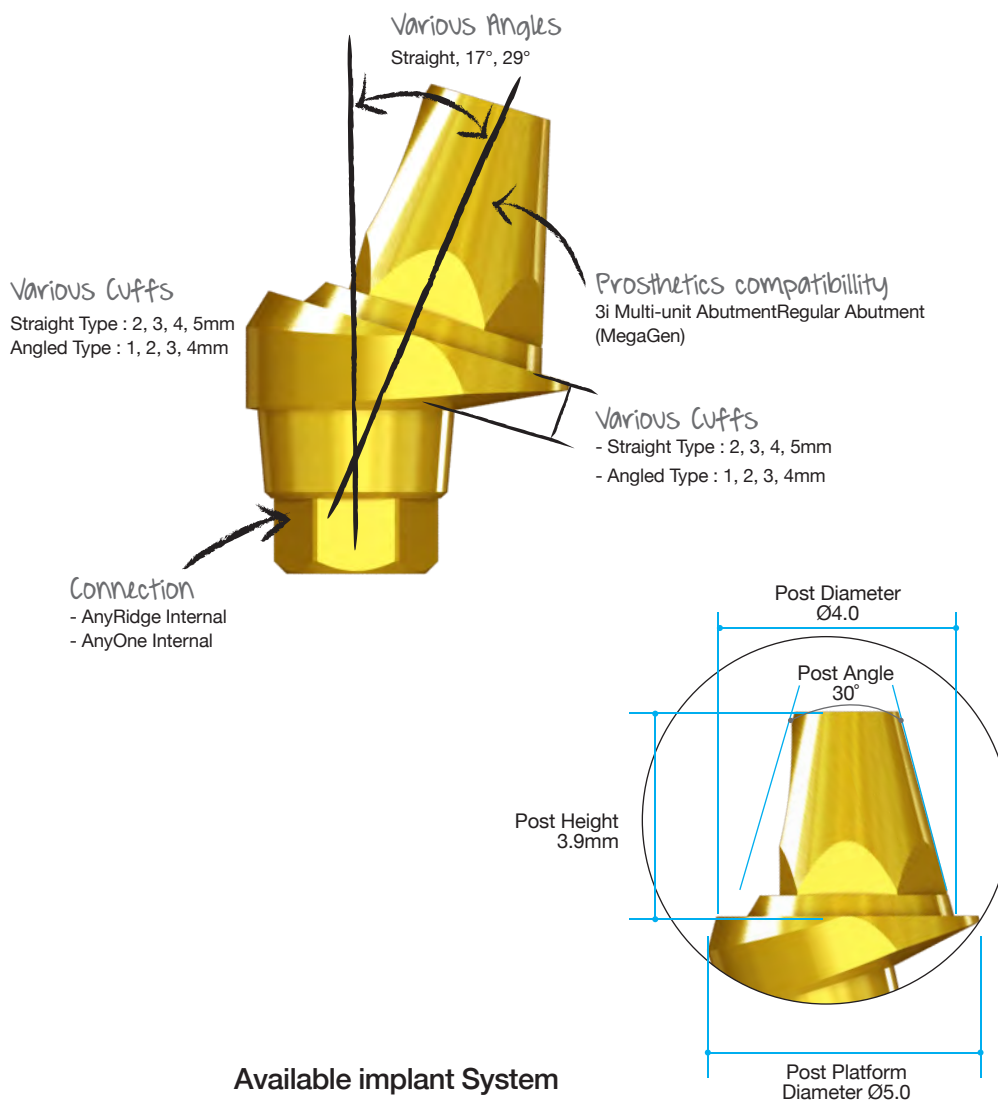

Benefit

1. Retrievability means that doctor can change or retrieve the final prosthetics easily.
2. Two types of angulation : 17°, 29°. It means that doctor has various options to angle.
3. Various cuff heights (1~5mm) : Doctor can have flexibility on the depth of fixture placement.
4. MegaGen's Multi-unit Abutment is perfectly compatible with the prosthetic components of Multi-unit Abutment of 3i implant, and Regular Abutment of MegaGen's Exfeel External system.

Available implant System

- AnyRidge Internal

II. Abutment Level Prosthesis

3-2. Multi-unit Abutment & Components

(All-on-4) (S-Type)

For the design concept and rationale of the Multi-unit Abutment, Please refer to page.100

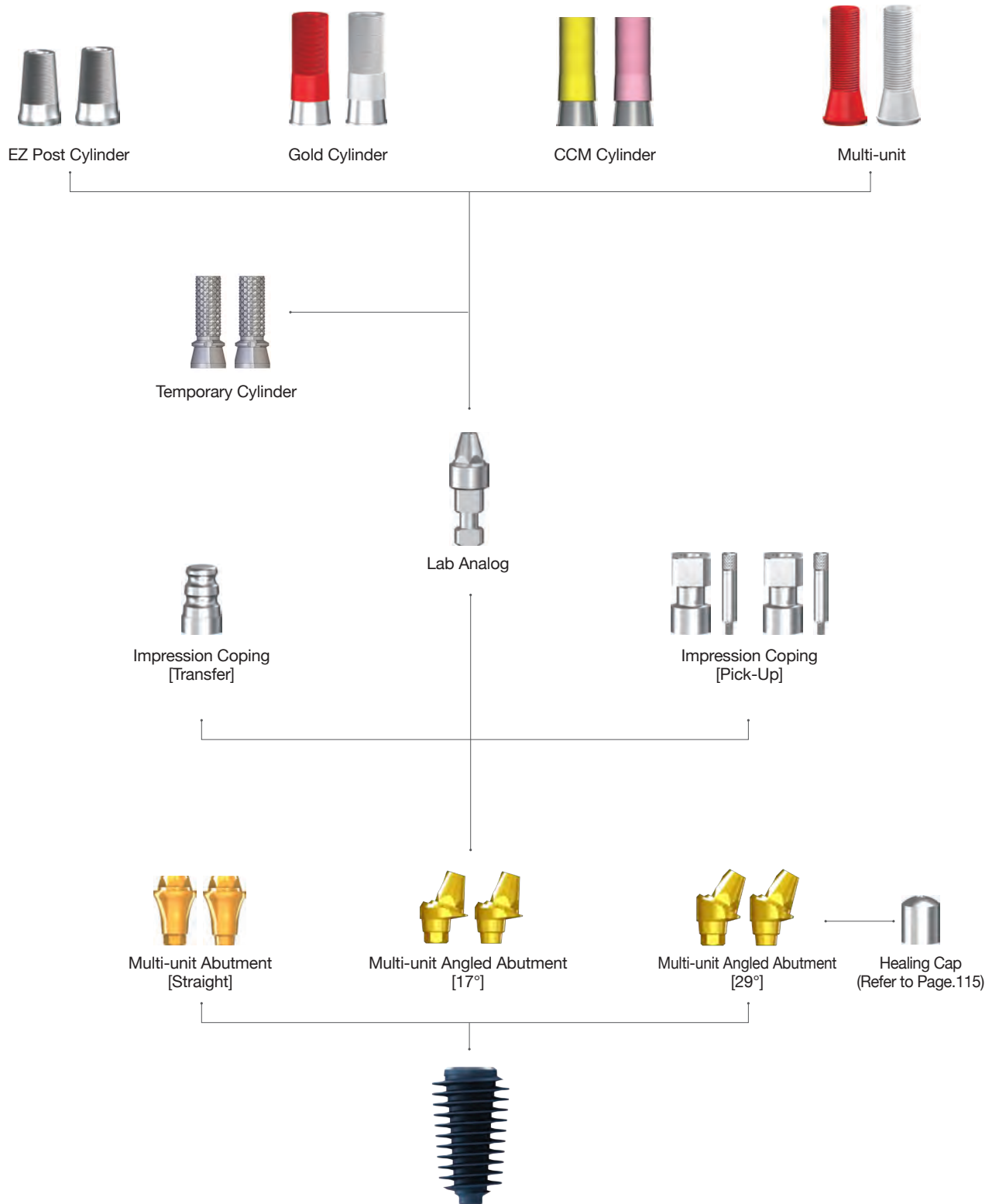

➔ Multi-unit Abutment

Multi-unit Abutment (Straight)

- Multi-unit Abutment Screw(AANMUS20) included.
- Use with Multi-unit Driver.
 - TCMMUDS20 (short)
 - TCMMUDL20 (long)
- Recommend torque : 35Ncm

Cuff Height (mm)	Type	Ref.C
2.0	Hex	AANMUH5020T
3.0		AANMUH5030T
4.0		AANMUH5040T
5.0		AANMUH5050T
2.0	Non-Hex	AANMUN5020T
3.0		AANMUN5030T
4.0		AANMUN5040T
5.0		AANMUN5050T

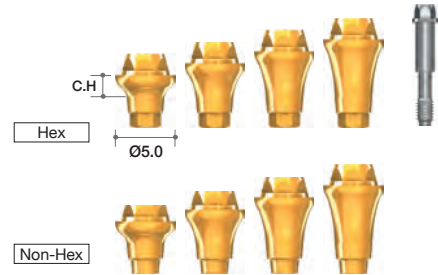

Multi-unit Angled Abutment (17°)

- Multi Post Screw(MUMSF/MUMST) included.
- Recommend torque : 35Ncm

Cuff Height (mm)	Type	Ref.C
1.0	Hex	AANMUH50117L
2.0		AANMUH50217L
3.0		AANMUH50317L
4.0		AANMUH50417L
1.0	Non-Hex	AANMUN50117L
2.0		AANMUN50217L
3.0		AANMUN50317L
4.0		AANMUN50417L



Multi-unit Angled Abutment (29°)

- Multi Post Screw(MUMSF/MUMST) included.
- Recommend torque : 35Ncm

Cuff Height (mm)	Type	Ref.C
1.0	Hex	AANMUH50129L
2.0		AANMUH50229L
3.0		AANMUH50329L
4.0		AANMUH50429L
1.0	Non-Hex	AANMUN50129L
2.0		AANMUN50229L
3.0		AANMUN50329L
4.0		AANMUN50429L



➔ Components for Multi-unit Abutment (Continued)

Lab Analog

Profile Diameter	Ref.C
Ø4.8	RELA300



Temporary Cylinder

- Cylinder Screw (TASH140) included
- Recommend torque : 15Ncm

Profile Diameter	Type	Ref.C
Ø4.8	Hex	ETH100T
	Non-Hex	ETN100T

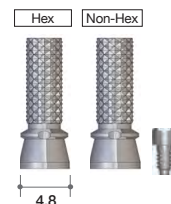

EZ Post Cylinder

- Cylinder Screw (TASH140) included
- Recommend torque : 15Ncm

Profile Diameter	Type	Ref.C
Ø5.0	Hex	RCA900T
	Non-Hex	RCA800T

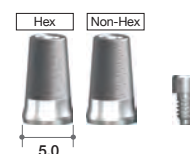

Healing Cap

Profile Diameter	Ref.C
Ø5.0	REC600



Impression Coping (Transfer)

Profile Diameter	Ref.C
Ø4.8	RITE480



Impression Coping (Pick-Up)

- Guide Pin (RICG150) included

Height (mm)	Type	Ref.C
9.4	Hex	RIEH480T
	Non-Hex	RIEN480T



Gold Cylinder

- Cylinder Screw (TASH140) included
- Useful to make a customized abutment in difficult situations.
- Precious and non-precious alloys.
- Melting point of gold alloy : 1063°C
- Threaded sleeves for convenient Resin / Wax-up.
- Recommend torque : 15Ncm

Profile Diameter	Sleeve Color	Ref.C
Ø5.0	Red	REGC200T
	White	REGC100T



CCM Cylinder

- Cylinder Screw (TASH140) included
- Useful to make a customized abutment in difficult situations.
- Can be casted with non-precious alloys (Ni-Cr, Cr-Co alloys).
- Non-precious melting temperature : Depends on Manufacturer
- Threaded sleeves for convenient Resin / Wax-up.
- Melting temperature of CCM : 1300~1400°C
- Recommend torque : 15Ncm

Profile Diameter	Sleeve Color	Ref.C
Ø4.8	Pink	RCA5013HT
	Yellow	RCA5013NT

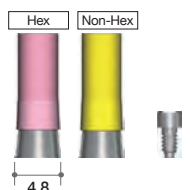

Plastic Cylinder

- Cylinder Screw (TASH140) included
- Recommend torque : 15Ncm

Profile Diameter	Sleeve Color	Ref.C
Ø5.2	Red	RPEH100T
	White	RPEN100T



II. Abutment Level Prosthesis

4. Flat Abutment & Components

:The main advantage of this Flat Abutment is the freedom on angulation.

Flat Abutment can cover any angulation problems.

: Only for multiple (Cannot be used for single implant)

: Only with screw-retained prosthetics.

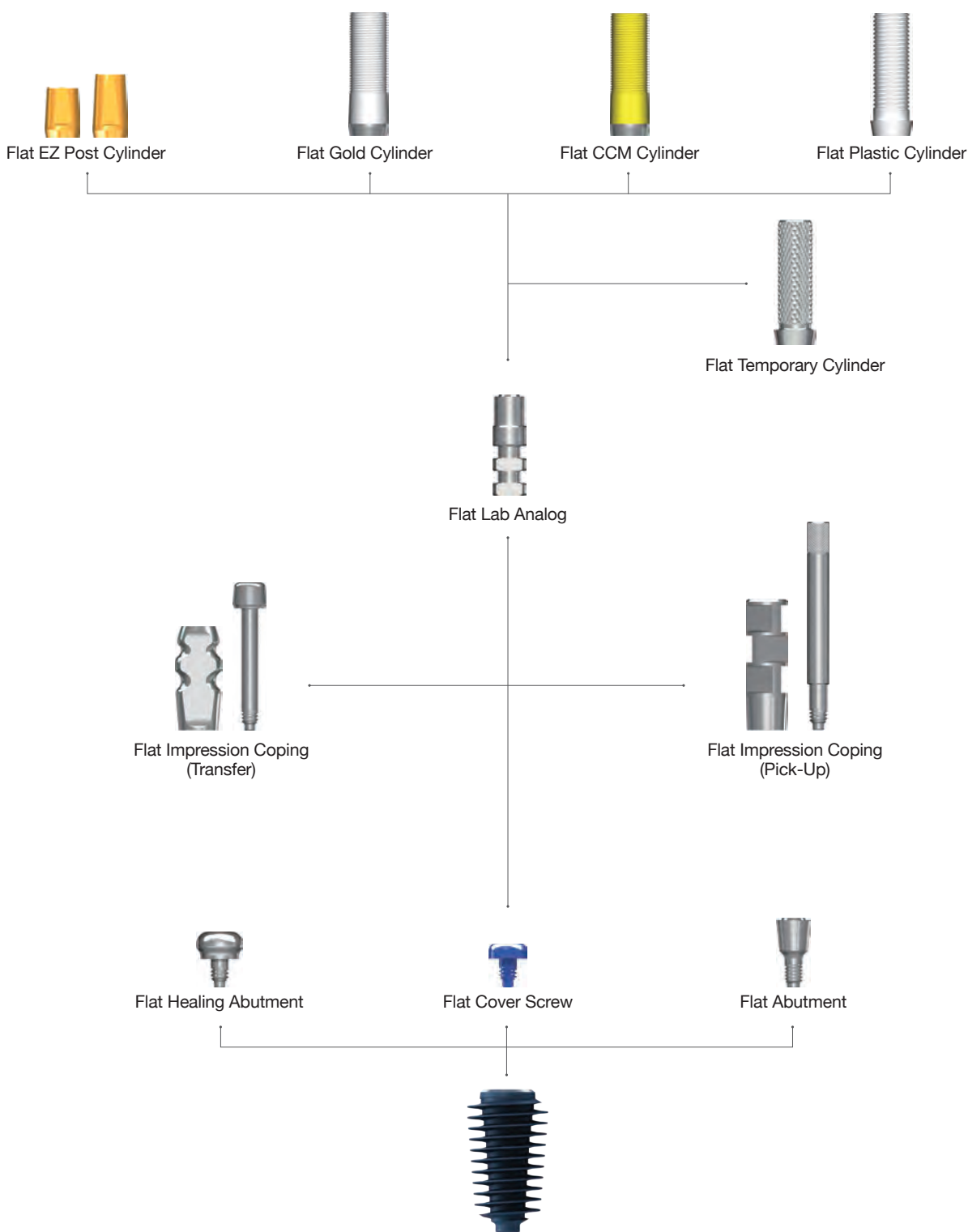

➔ Components for Flat Abutment (Continued)

Flat Abutment

- Use Hand Driver (1.6 Hex)
- Recommend torque : 25Ncm

Profile Diameter	Cuff Height (mm)	Ref.C
Ø3.5	1	AANFAL3510
	2	AANFAL3520
	3	AANFAL3530
	4	AANFAL3540
	5	AANFAL3550



Flat Cover Screw

- Recommend torque : by hand (5 - 8Ncm)

Profile Diameter	Ref.C
Ø3.5	FCS3510

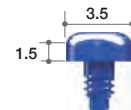

Flat Healing Abutment

- Recommend torque : by hand (5 - 8Ncm)

Height(mm)	Ref.C
2	FHA402
3	FHA403
4	FHA404



Flat Impression Coping (Transfer)

- Guide Pin (FGPT) included.
- Should be tightened with Impression Driver (Page. 405)
- Special impression coping screw which can be used with a 1.2mm hex driver is available on request.

Profile Diameter	Height (mm)	Ref.C
Ø3.5	9.5	FIT4012T



Flat Impression Coping (Pick-Up)

- Guide pin (FGPP15) included.

Profile Diameter	Height (mm)	Ref.C
Ø3.5	12	FIP4012T

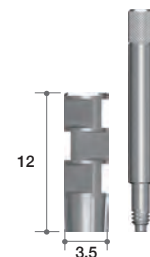

Flat Lab Analog

Profile Diameter	Height (mm)	Ref.C
Ø3.5	12	FLA3512



➔ Components for Flat Abutment

Flat Temporary Cylinder

- Flat Cylinder Screw (FAS) included.
- Recommend torque : 15Ncm

Profile Diameter	Ref.C
Ø4.0	FTC4012T



Flat EZ Post Cylinder

- Flat Cylinder Screw (FAS) included.
- Recommend torque : 25Ncm

Height (mm)	Ref.C
5.5	FEC4005T
7.0	FEC4007T



Flat Gold Cylinder

- Flat Cylinder Screw (FAS) included.
- Useful to make a customized abutment in difficult situations.
- Precious and non-precious alloys.
- Melting point of gold alloy : 1400 - 1450°C
- Threaded sleeves for convenient Resin / Wax-up.
- Recommend torque : 25Ncm

Profile Diameter	Ref.C
Ø3.8	FGC4012T



Flat CCM Cylinder

- Flat Cylinder Screw (FAS) included.
- Useful to make a customized abutment in difficult situations.
- Can be casted with non-precious alloys (Ni-Cr, Cr-Co alloys).
- Non-precious melting temperature : Depend on Manufacturer
- Threaded sleeves for convenient Resin / Wax-up.
- Melting temperature of CCM : 1300~1400°C
- Recommend torque : 25Ncm

Profile Diameter	Ref.C
Ø3.8	FCC4012T

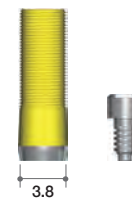

Flat Plastic Cylinder

- Flat Cylinder Screw (FAS) included.
- Recommend torque : 25Ncm

Profile Diameter	Ref.C
Ø4.0	FPC4012T



III. Overdenture Prosthesis

1. MegaGen Overdenture System

Meg-Loc

Compatible with products L & K, excellent functionality, & incomparable price!

Combination of Titanium housing and Pekkton (reinforced plastic) creates low water solubility and higher wear resistance and durability than other existing products.

Retention insert offers wide range of retention forces (600gf, 1200gf, 1800gf) to suit each patient, resulting in high level of satisfaction for both patient and dentist. Strong physical properties of Pekkton and insert gap increase elasticity, so that insert does not tear or break unlike conventional nylon products, thereby ensuring strong retention and longer life.



Meg-Ball

Smallest housing, retentive ring with longer life!
Even when the implant angle is not parallel, a stable denture can still be produced!

Compatible with other products with Ø2.25 head size, minimized patient inconvenience due to small-size housing, simpler to arrange artificial teeth as space occupied by denture is reduced, and easier to maintain than other systems.

Retentive ring has a high elasticity, abrasion resistance, and durability, thereby doubling the length of life when compared to a silicone O-ring and guaranteeing a longer life than NBR products.

Positioner (0/5/10/15 degrees) maintains parallel housing direction, even with distorted implant placement angle, ensuring denture stability.

Meg-Magnet

Designed to maintain stable & sufficient magnetic force!
Completely blocks bursts & corrosion resistant!

Structure is connected with abutment using magnetic force, which is feasible even with insufficient bone volume or poor bone quality

Easy to attach and detach, and minimal inflammation.

Magnet of Ø4.5 & Ø5.0 is compatible with other products, and laser marking on upper part makes it easy to distinguish between up and down.

Sufficient magnetic force ensures stable retention

Laser sealing blocks any bursting phenomenon.

TiN coating provides corrosion resistance.

Positioner (small & regular) prevents magnet from slipping in the mouth and stops any flow of impression materials under the abutment.

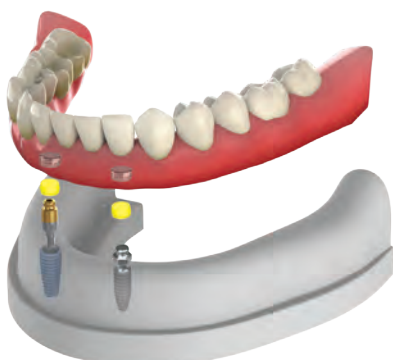

Meg-Rhein

Can compensate for tilted implant placement angle up to 50°

Combined head and housing structure is smallest on the market.

Retentive cap is based on Italian technology and has uniform physical properties. Various retention forces (600gf, 1200gf, 1800gf, 2700gf) classified by color can be selected according to each patient.

Dynamic housing with double structure enables tilting to 25° angle, allowing stable denture even when with distorted implant placement angle.

III. Overdenture Prosthesis

2. Meg-Loc Abutment & Components



Meg-Loc Metal Housing set



Block-out Spacer



Meg-Loc Abutment



►► Meg-Loc Overdenture System

Advantages

Easy compatibility

Compatible with Product L and Product K (same specifications)

Better abrasion resistance and durability

Combination of Titanium housing and reinforced plastic (Pektkton) provides low water solubility and high resistance, making it superior in abrasion resistance and durability compared to existing products.

Water Sorption Test

Property	Meg-Loc (Pektkton)	Product L	Unit
Water Sorption	8.7	93.5	µg/mm ³

Stronger retention and longer life

Strong physical properties of Pektkton and gap in insert increase the elasticity, preventing the insert from being torn or broken unlike existing nylon products, even when angle does not match when attaching & removing denture.

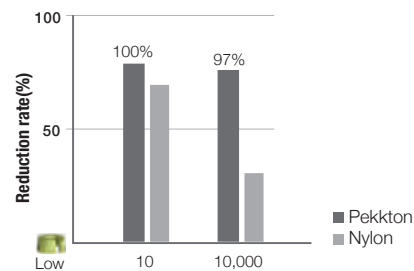

Easy to use

High resistance to plaque and easy cleaning
Easy replacement of retention insert

Tilting Angle



Various Retentive Caps of the Meg-Loc

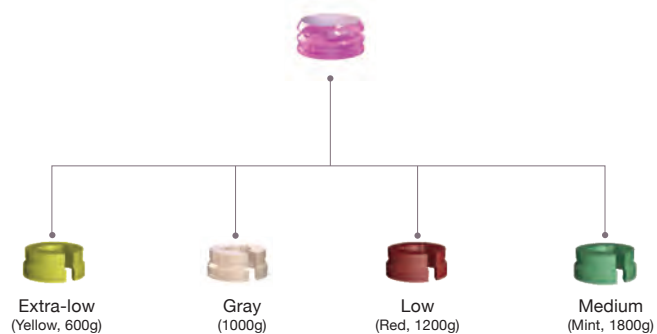

➔ Meg-Loc Overdenture System

Meg-Loc Abutment

- Angle compensation to one side 20 ° (both sides 40 °)
- Gently rounded shape
- Compatible with 1.2 Hex Driver
- Recommend torque : 35Ncm

Cuff Height (mm)	Ref.C
0	MLAR00
1.0	MLAR01
2.0	MLAR02
3.0	MLAR03
4.0	MLAR04
5.0	MLAR05
6.0	MLAR06
7.0	MLAR07



Meg-Loc Package

- 1 Meg-Loc Abutment

* Following package items are delivered with San DreMetto Korea packaging.

- 1 Titanium Housing
- 1 Block Out Spacer
- 4 Pekkton Retention Inserts (Yellow-600gf(for lab), Gray-1000gf, Red-1200gf, Mint-1800gf)

Cuff Height (mm)	Ref.C
0	MLAR00P
1.0	MLAR01P
2.0	MLAR02P
3.0	MLAR03P
4.0	MLAR04P
5.0	MLAR05P
6.0	MLAR06P
7.0 </td <td>MLAR07P</td>	MLAR07P



Meg-Loc Attachment

Description	QTY	Ref.C
CM-LOC Attachment	SET	CM-LOC
Housing Titanium® for Pekkton® Inserts	4EA	CM-LOC-TP
Processing Insert (extra-low)	4EA	CM-LOC-PI
Insert (extra-low)	4EA	CM-LOC-EL
Insert (low)	4EA	CM-LOC-L
Insert (medium)	4EA	CM-LOC-M
Block-out Spacer	4EA	CM-LOC-BS
Impression Part	4EA	CM-LOC-IP
Analog	4EA	CM-LOC-AN

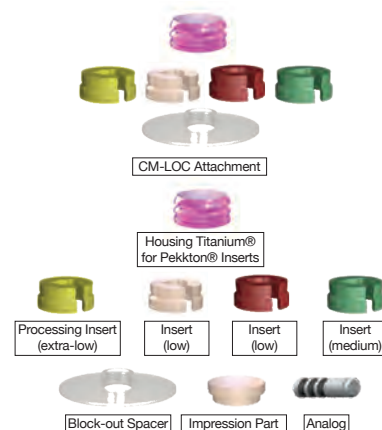

Multi Tool

- Retention Insert Insertion & Removal Tool

Ref.C
MLMT

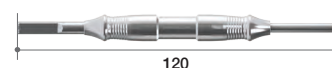

III. Overdenture Prosthesis

3. Meg-Ball Abutment & Components



Meg-Ball Metal Housing set



Housing Positioner
(0°/5°/10°/15°)



Meg-Ball Abutment



►► Meg-Ball Overdenture System

Advantages

Easy compatibility



Ø2.25 head size for easy compatibility with other products

Smallest Housing



Metal Housing

Small housing minimizes patient inconvenience, facilitates arrangement of artificial teeth by reducing space occupied by denture, and is easier to maintain than other systems.

Double length of life



Retentive Ring

High elasticity, abrasion resistance, and durability doubles the length of life when compared with silicone O-ring and guarantees longer life than NBR products.

Stable denture even when implant placement angle is distorted

Positioner (0/5/10/15 degrees) maintains parallel housing direction even when angle of implant placement is distorted, ensuring denture stability

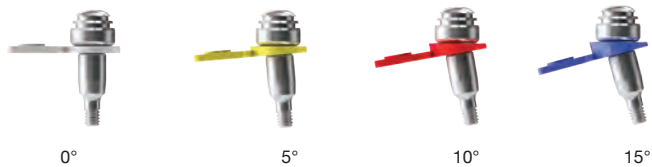

Tilting Angle



➔ Meg-Ball Overdenture System

Meg-Ball Abutment

- Angle compensation to one side 15 ° (both sides 30 °)
- Ø2.25 Ball shape
- Recommend torque : 35Ncm

Cuff Height (mm)	Ref.C
0	MBAR00
1.0	MBAR10
2.0	MBAR20
3.0	MBAR30
4.0	MBAR40
5.0	MBAR50
6.0	MBAR60
7.0	MBAR70

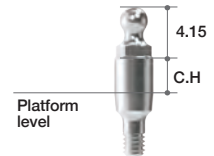

Meg-Ball Package

- Composed of Meg-Ball Abutment/ Metal Housing Set/ Housing Positioner (0°,5°,10°,15°)

Cuff Height (mm)	Ref.C
0	MBAR00P
1.0	MBAR10P
2.0	MBAR20P
3.0	MBAR30P
4.0 </td <td>MBAR40P</td>	MBAR40P
5.0	MBAR50P
6.0	MBAR60P
7.0	MBAR70P



Meg-Ball Metal Housing Set

- 1 Metal Housing
- 1 Retentive Ring

Ref.C
MBHR



Retentive Ring Set

Quantity	Ref.C
5	MBR5
10	MBR10



Ball Driver

- For seating of the Ball Abutment into the fixture.
- Can connect to a Handpiece, Ratchet or Torque Wrench.
- Available in long and short.
- Refer to Page. 374

Type	Ref.c
Toque Driver(Short)	TBT250S
Toque Driver(Long)	TBT250L

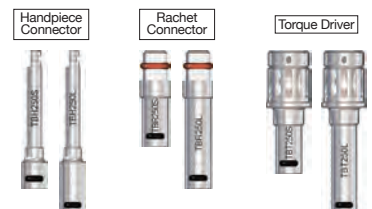



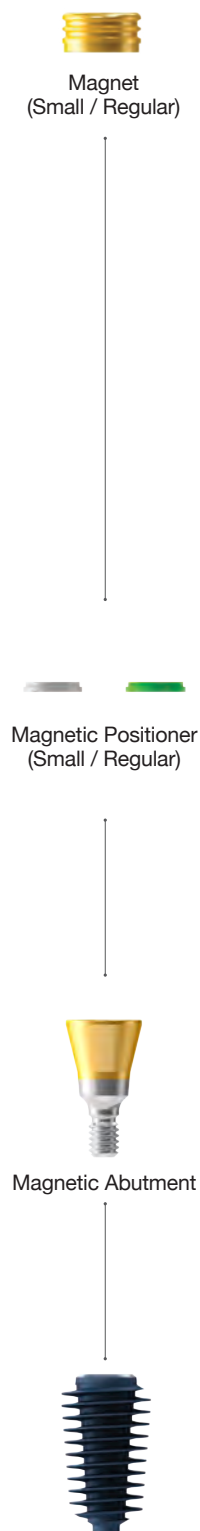

III. Overdenture Prosthesis

4. Meg-Magnet Abutment & Components

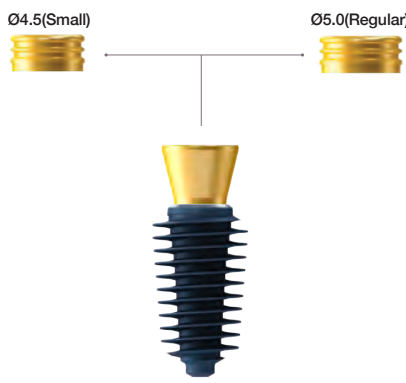

►► Meg-Magnet Overdenture System

<p>Advantages</p> <p>Easy to apply for elderly patients or disabled patients</p> <p>Designed for maximum magnetic efficiency and durability</p> <p>Outstanding retention</p> <ul style="list-style-type: none"> - Blocks bursting - Corrosion resistant - Abrasion resistant <p>Easy to distinguish between up and down via laser marking on upper section</p> <p>No slippage of magnet</p>	<p>Applicable with insufficient bone volume and poor bone quality</p> <p>Easy to attach and detach</p> <p>Unlikely to cause inflammation</p> <p>Sufficient magnetic force (450gf, 650gf) to ensure stable retention</p> <p>Laser sealing blocks any bursting phenomenon</p> <p>TiN coating provides corrosion resistance</p> <p>Over 0.1mm thickness at contact with attachment to ensure wear resistance</p>  <p>Magnet of Ø4.5 & Ø5.0 is compatible with other products</p> <p>Laser marking on upper part makes it easy to distinguish between up and down</p> <div style="display: flex; justify-content: space-around; align-items: center;"> <div style="text-align: center;">  <p>S</p> </div> <div style="text-align: center;">  <p>R</p> </div> </div> <p>Positioner (small & regular) prevents magnet from slipping in mouth and stops any flow of impression materials under the abutment</p> <div style="display: flex; justify-content: space-around; align-items: center;"> <div style="text-align: center;"> <p>Small</p>  <p>Ø4.5 (350-450gf)</p> </div> <div style="text-align: center;"> <p>Regular</p>  <p>Ø5.0 (550-650gf)</p> </div> </div>
<p>Component of the Meg-Magnet</p>	

➔ Meg-Magnet Overdenture System

Meg-Magnet Abutment

- Use to 1.2 Hex Driver
- Recommend torque : 35Ncm

Profile Diameter	Cuff Height (mm)	Ref.C
Ø4.5	0	MMAR400
	1.0	MMAR410
	2.0	MMAR420
	3.0	MMAR430
	4.0	MMAR440
	5.0	MMAR450
	6.0	MMAR460
Ø5.0	7.0	MMAR470
	0	MMAR500
	1.0	MMAR510
	2.0	MMAR520
	3.0	MMAR530
	4.0	MMAR540
	5.0	MMAR550
	6.0	MMAR560
	7.0	MMAR570

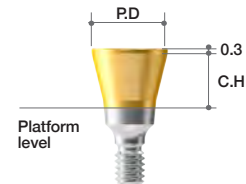

Meg-Magnet Package

- 1 Meg-Magnet Abutment
- 1 Magnet (Ø4.5-S, Ø5.0-R)
- 1 Magnetic Positioner

***Caution!**

[Magnetic Positioner]

- Use according to the standard
- : Small(White)/ Regular(Green)
- Do not reuse

[Magnet]

- Do not heat above 70°C
- : Loss of magnetism at high temperatures
- : If sterilization is required, alcohol disinfection is recommended, not autoclave
- Remove if taking MRI.
- No direct contact between products during the procedure
- : Difficulty in separation due to attraction between magnets

Profile Diameter	Cuff Height (mm)	Ref.C
Ø4.5	0	MMAR400P
	1.0	MMAR410P
	2.0	MMAR420P
	3.0	MMAR430P
	4.0	MMAR440P
	5.0	MMAR450P
	6.0	MMAR460P
Ø5.0	7.0	MMAR470P
	0	MMAR500P
	1.0	MMAR510P
	2.0	MMAR520P
	3.0	MMAR530P
	4.0	MMAR540P
	5.0	MMAR550P
	6.0	MMAR560P
	7.0	MMAR570P



Meg-Magnet Attachment Set

Size	Ref.C
Small	MA402
Regular	MA502

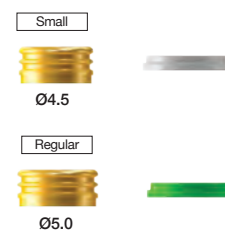

III. Overdenture Prosthesis

5. Meg-Rhein Abutment & Components

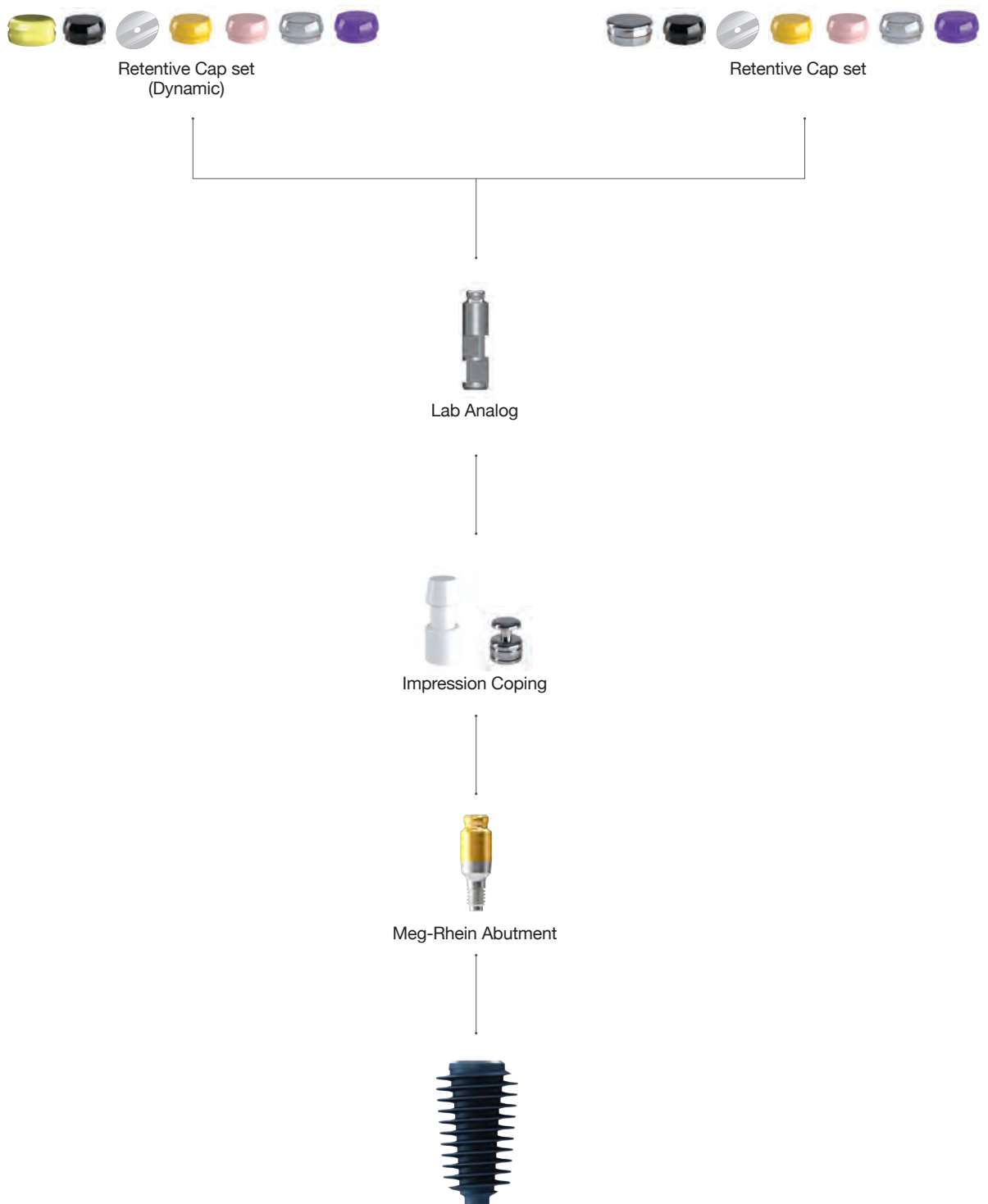

➔ Meg-Rhein Overdenture System

Meg-Rhein Overdenture System (Dynamic)

- 1 Meg-Rhein Abutment
- 1 Plastic Impression Coping
- 1 Stainless Steel Housing (Dynamic) & Black-Lab
- 1 Protective Disk
- 4 Retentive Caps (Yellow-0.6kgf, Pink-1.2kgf, White-1.8kgf, Violet-2.7kgf)

- Perfect compatibility with the Rhein83 from Italy.
- Recommend torque : 15Ncm.

Cuff Height (mm)	Ref.C
0	ADR00PA
1.0	ADR01PA
2.0	ADR02PA
3.0	ADR03PA
4.0	ADR04PA
5.0	ADR05PA
6.0	ADR06PA

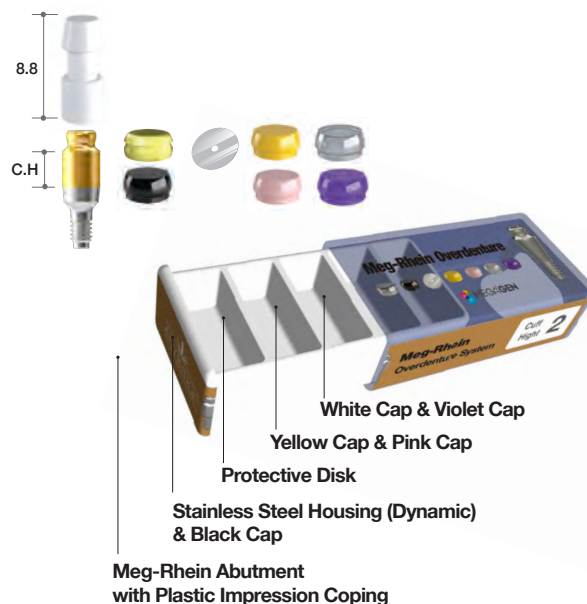

Meg-Rhein Overdenture System

- 1 Meg-Rhein Abutment
- 1 Plastic Impression Coping
- 1 Stainless Steel Housing
- 1 Protective Disk
- 5 Retentive Caps (Black-Lab, Yellow-0.6kgf, Pink-1.2kgf, White-1.8kgf, Violet-2.7kgf)

- Perfect compatibility with the Rhein83 from Italy.
- Recommend torque : 15Ncm.

Cuff Height (mm)	Ref.C
0	ADR00P
1.0	ADR01P
2.0	ADR02P
3.0	ADR03P
4.0	ADR04P
5.0	ADR05P
6.0	ADR06P



►► Overdenture System

Advantages

Small & Easy-to-Use Housing System 

Tilting Angle

Various Retentive Caps of the Meg-Rhein

Low Reduction Rate & Uniform Variance of Retentive Force

Normal

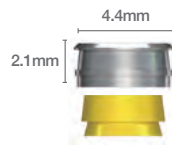

Dynamic

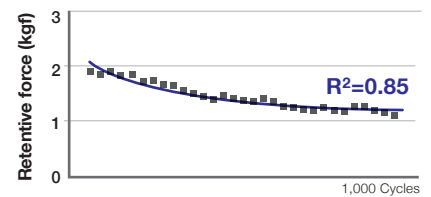
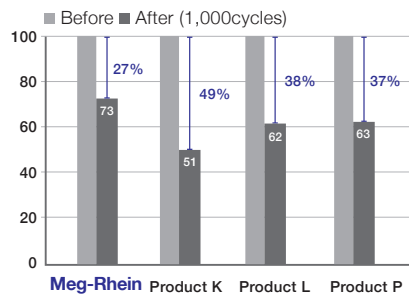
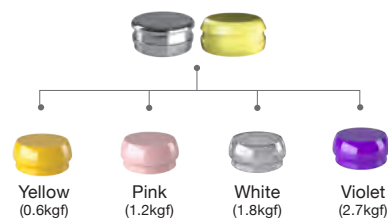
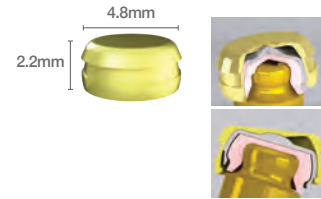

R^2 (Coefficient of determination) becomes more reliable when it is close to "1".

➔ Components for Meg-Rhein Abutment

Stainless Steel Housing

- 5ea/pack

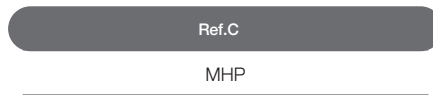

Stainless Steel Housing (Dynamic)

- 5ea/pack

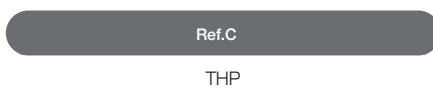

Retentive Caps (White)

- White cap(1.8kgf) - For refill (5ea/pack).
- Can be used for more retentive force following pink cap(1.2kgf).

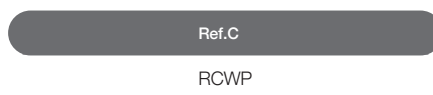

Retentive Caps (Violet)

- Violet cap(2.7kgf) - For refill (5ea/pack).
- Can be used for more retentive force following white cap(1.8kgf).

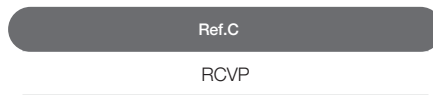

Retentive Caps (Pink)

- Pink cap(1.2kgf) - For refill (5ea/pack).

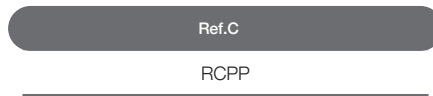

Retentive Caps (Yellow)

- Yellow cap(0.6kgf) - For refill (5ea/pack).

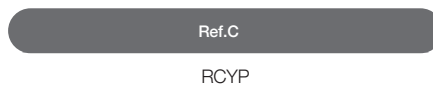

Retentive Caps (Black)

- For laboratory

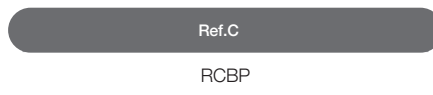

Stainless Impression Coping (Pick-Up)

- 2ea/pack.
- Italy - Rhein 83 products.
- For accurate (pick-up type) impression.
- Metal with groove design to prevent from swaying.

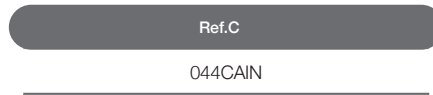

Lab Analog

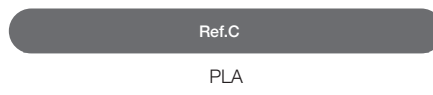

Retentive Cap Removal Tool

- Retentive Cap removal tool.

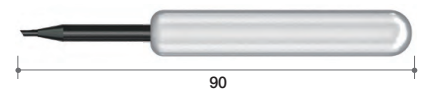
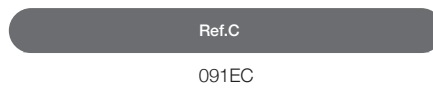

Retentive Cap Insertion Tool

- Retentive Cap insertion tool.

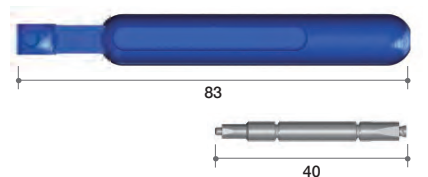
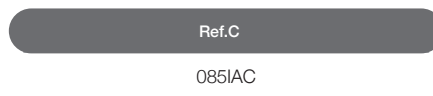

Why will AnyRidge work in any ridge?

Narrow upper diameter

To maximize preservation by minimizing stress on the cortical bone.

XPEED®

For faster, stronger osseointegration. New surface technology incorporating Ca²⁺ ions on the SLA treated surface. 100% elimination of any remaining acid from the conventional SLA process.

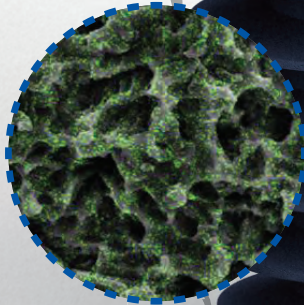

Wider fixture in a narrow crest

To maximize long term survival of implants.

Knife-Threads

For smooth insertion and stronger primary stability. No cutting edge for minimum invasion. Ideal for soft bone cases.

Tapered body

Excellent for simple installation and Immediate loading.

Narrow apical diameter

For easier fixture insertion into a narrow ridge split incision

Case1

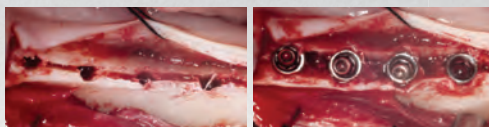

Case2



final restoration

AnyRidge Clinical Case

➔ Clinical Case 1

- Courtesy of Dr. Kwang-Bum Park

AnyRidge implant has excellent surface treatment which can be osseointegrated at this extreme case of bone defect.

Fig 1. This patient was 56 years old male patient and had a chief complaint of chewing difficulty on the left first mandibular molar due to periodontitis. On the panoramic radiograph, the tooth was floated with complete bone loss to the apex, and there was not enough bone to get initial stability for implant placement at the apex above mandibular nerve. So I decided to extract the tooth and wait for 4 months for regeneration of the socket.

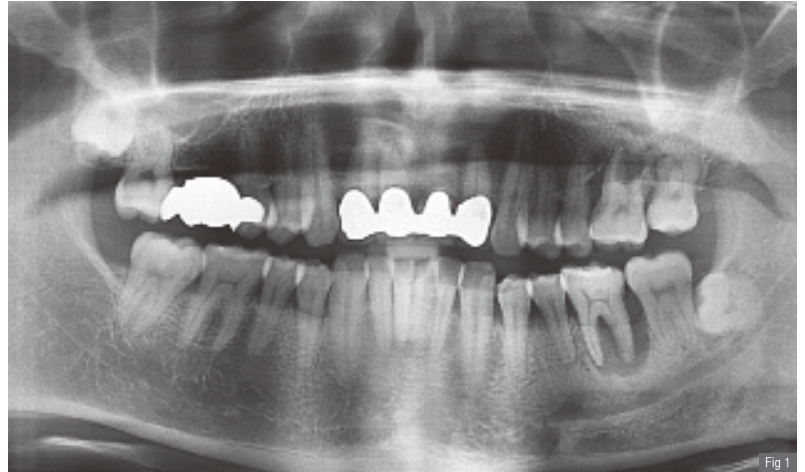

Fig 2. The patient came back to my office after 4 months. Healing appeared good enough clinically, but the panoramic view still showed large socket defect. In many cases like this, we can expect some amount of bone filled in the socket which can allow minimal initial stability for implant placement.

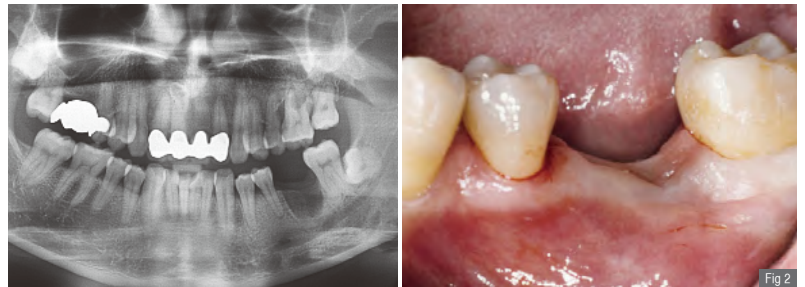

Fig 3. When the flap was opened, I was very embarrassed that bone regeneration did not occur in the socket. None of remaining bone could be used for implant fixation.



Fig 4. A widest AnyRidge implant 8.0mm was placed on the mesial wall of extraction socket, but there was no initial stability. This trial was quite heroic treatment, but there was no other option except this because he spent many hours for this surgery.

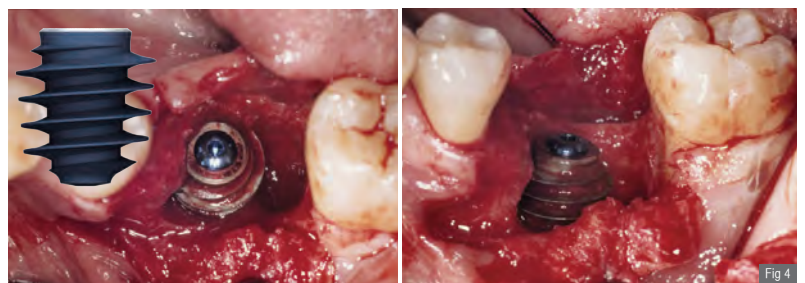

Fig 5. The mixture of Allograft (Mega-Oss) and Synthetic bone (Bone Plus) was placed into the remaining socket defect and a collagen membrane was covered. Then primary closure was made with incision release on the periosteum.



Fig 6. On the panoramic view after surgery, we could find that none of the fixture was engaged with remaining bone, so it had more than 1.6mm gap from the tip to the depth of knife threads. I worried about the bone filling and success of the osseointegration on this fixture.

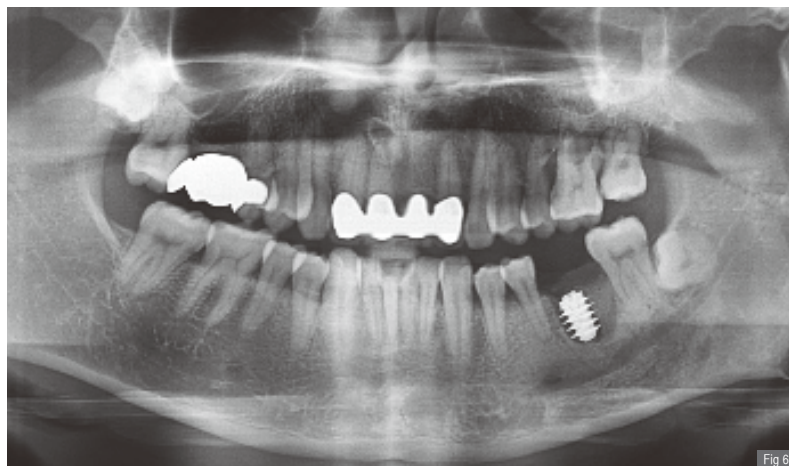

Fig 7. However, I was surprised with the hard cortical bone regeneration over the cover screw when I did the second stage surgery with the Biolaser.



Fig 8. On the intraoral radiograph taken several weeks after second surgery, we could see the fully regenerated bone into the bottom of thread depth.



Fig 9. The patient came back to our office to get one more implant on the maxillary upper molar after 2 years from the first implant surgery. The regenerated bone was matured and showed very stable crestal bone on the intraoral radiograph.

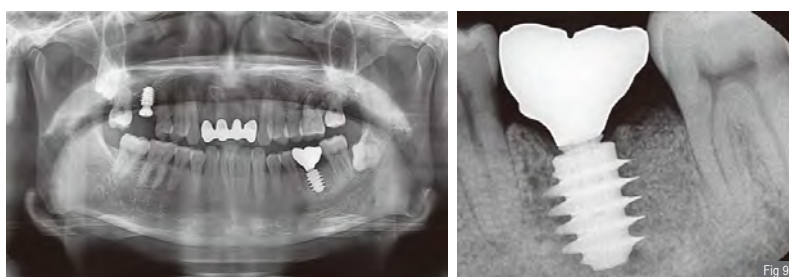

➔ Clinical Case 2

- Courtesy of Dr. Kwang-Bum Park

Advantage of fuse abutment with AnyRidge implant for immediate loading in upper fully edentulous case

Fig 1. An 80-year-old female patient presented with discomfort related to her upper teeth. About 10 years previously she underwent implant surgery in the mandible and received temporary teeth immediately as the bone density was sufficient for immediate loading. The patient requested a treatment plan for the upper arch that would give her immediate teeth.

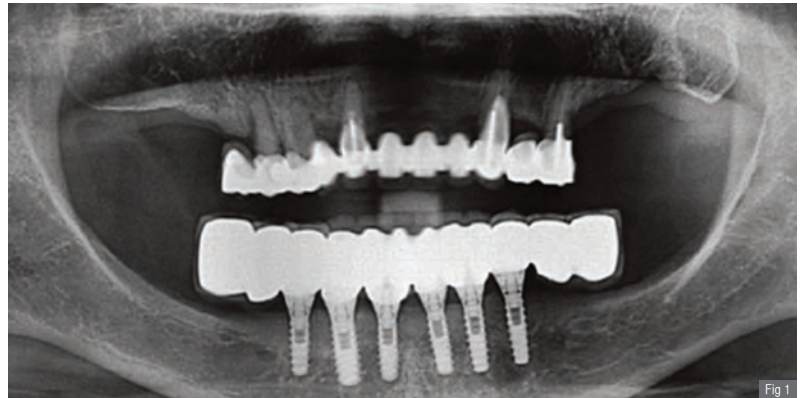

Fig 2. Clinical photos before surgery. The patient had no discomfort or complaints related to her mandibular implants. Plus her hygiene control was very good for maintaining healthy peri-implant tissue.



Fig 3. All the remaining teeth were extracted. As shown, some teeth had severe periodontitis and some had decay at the cervix of the tooth. Drilling up to 2.9 mm was conducted at each implant site and eight 3.5x15mm implant fixtures were placed using a minimal flap design. All the fixtures showed excellent initial fixation, and the immediately-placed implants only had small socket defects.



Fig 4. Eight fuse abutments were connected and the flaps were sutured to create a tight sealing against the fuse abutments



Fig 5. The fuse abutments were prepared using a high speed handpiece for a temporary bridge that was already made before the implant surgery

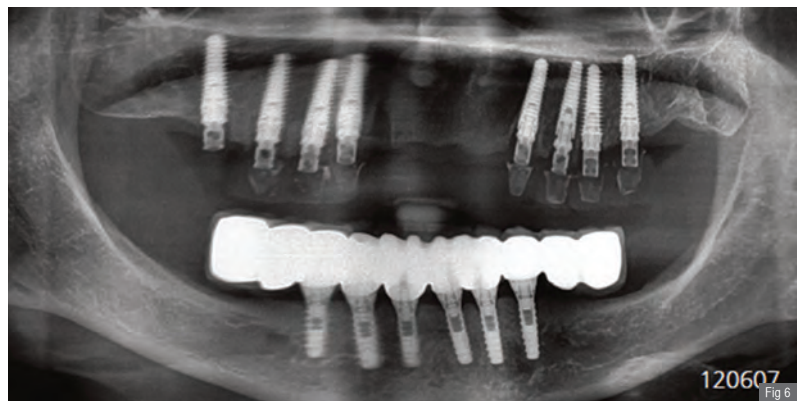
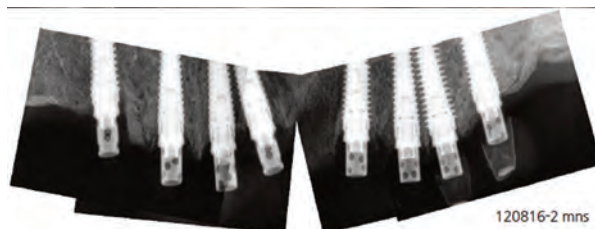

Fig 6. Panoramic scan taken immediately after surgery. The first premolar implant showed some mis-fit between the crown and the ratio.

Fig 7. Intraoral scans taken 2 months after surgery. Shadows of the extraction socket can still be seen, but regenerated bone has started to fill the socket defects. The fuse abutments are functioning well without any problem. An impression was taken for customized zirconia abutments



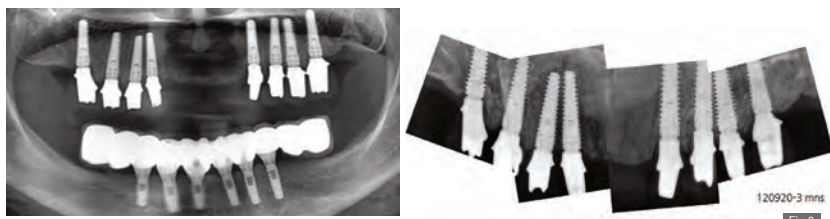

Fig 8. Panoramic & intraoral scans taken 3 months after surgery. Zirconia customized abutments were connected to each fixture. The socket defects are completely filled with regenerated bone even in the case of immediate loading on the immediately placed implants.



Fig 9. Clinical photos of zirconia customized abutments and PMMA temporary bridge made using CAD/CAM technique. A zirconia abutment is excellent for both esthetics and hygiene maintenance. It has less than 1/10 bacterial accumulation on the surface compared with metals including titanium. PMMA provisional bridge is stronger than tooth resin, especially at the margin, so much beneficial for functional and occlusal tests.

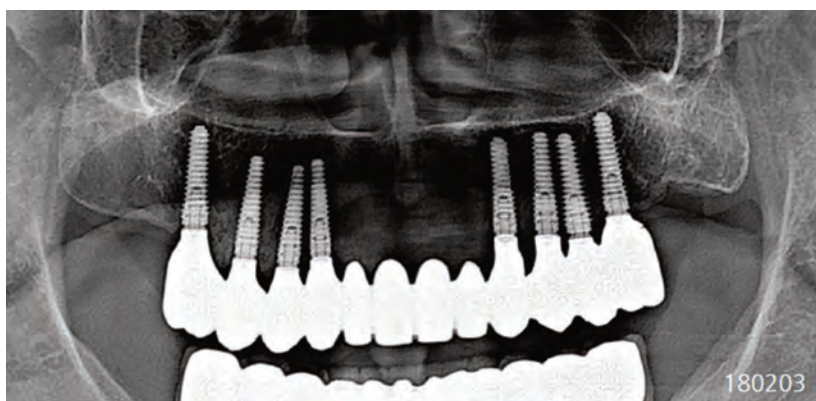

Fig 10. A full zirconia one-piece bridge was made and delivered. The patient was very satisfied with the results, and thankful that she was provided with 'teeth' from the beginning to the end.



Fig 11. Panoramic scan of final restorations on day of delivery

Fig 12. Panoramic scans at 7 years follow-up



➔ Clinical Case 3

- Courtesy of Dr. Soheil Bechara

Simultaneous sinus lift and implant placement

Fig 1. The patient presented with huge bony defects around residual roots in the upper jaw. The treatment plan was to perform immediate implant placement and extract all decayed roots during one surgical session, as the patient had only one week to stay in the country.

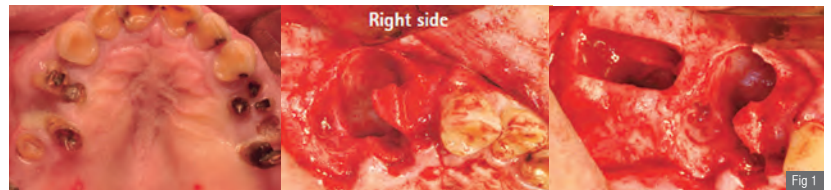

Fig 2. Lateral window sinus lifting was performed on the right side with simultaneous implant placement in tooth area 17. In area 14 we can observe a huge bony defect which was thoroughly debrided until the margins of healthy bone. The Osteotomy was prepared with a 2mm final drill to place a 3.5x15mm Anyridge implant.



Fig 3. 3.5x15mm Anyridge implant was placed having only 2mm contact with the bone in the coronal part achieving 25 Ncm of initial torque.

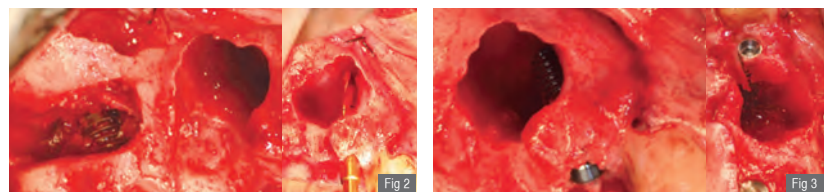

Fig 4. The bony defect was filled with a Xenograft and covered with a collagen membrane. Although the defect is huge but it is still considered as an intra-bony defect with a good potential of bone regeneration.

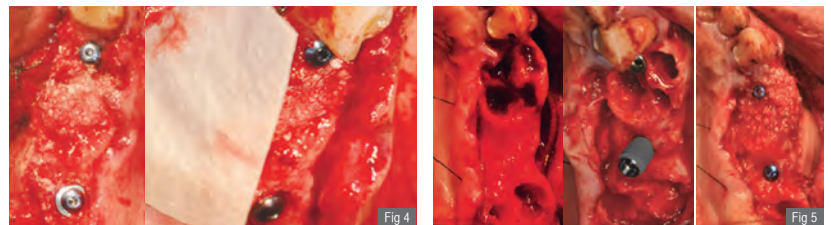
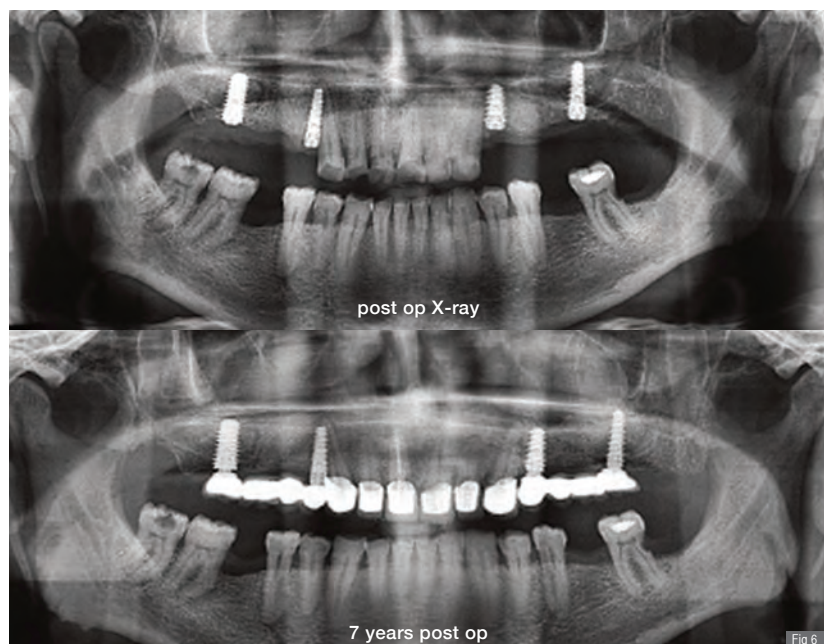

Fig 5. On the left side two Anyridge implants were placed, immediate implant placement in area 24. Sinus lift with simultaneous implant placement in area 27.



➔ Clinical Case 4

- Courtesy of Prof. Giuseppe Luongo

Immediate post-extraction insertion of implant and immediate loading.

Before Surgery

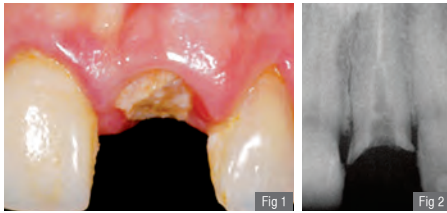

Fracture of #21 tooth. Good stability of the hard and soft tissues suggests immediate post-extraction insertion of implant and immediate loading.

Surgery

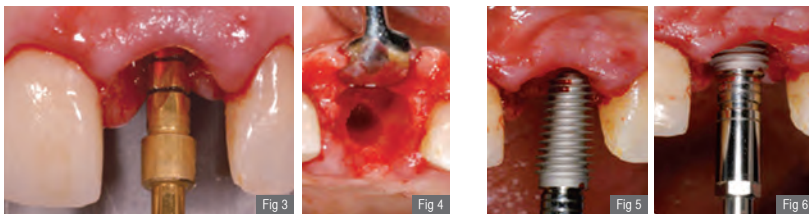

To protect the esthetic outcome of the procedure, the implant site was prepared via slightly palatal alveolar access.

A 4.5x11mm Anyridge was placed in the prepared site.

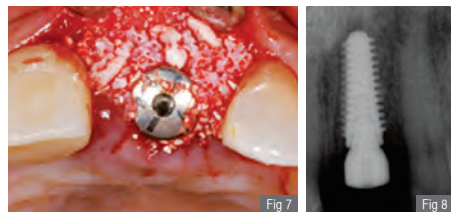

Biomaterial was added to the vestibular aspect to improve the stability of the esthetic outcome.

Temporary Prosthesis



A temporary crown was immediately placed.

12 Weeks after surgery



Tissue was ready to proceed with final abutment and crown.

Final Prosthesis



The implant position was in harmony with the surrounding tissue and a prosthodontist completed the case using a zirconia framework.

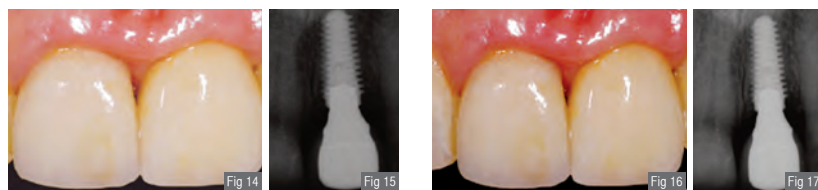

Fig 1. Clinical photos.

Fig 2. Intraoral scan.

Fig 3, 4. Clinical photos of 1st surgery.

Fig 5, 6. Clinical photos of implant positioning.

Fig 7, 8. Clinical photo & scan of surgery.

Fig 9, 10. Clinical photos of immediate temporary crown in place.

Fig 11, 12. Clinical photos of healing and final abutment in place.

Fig 13. Clinical photo of zirconia framework in place.

Fig 14, 15. Clinical photo & intraoral scan of final crown at time of placement.

Fig 16, 17. Clinical photo & intraoral scan of final crown at 1-yr follow-up.

Fig 18, 19. Clinical photo & intraoral scan of final crown at 5-yr follow-up.

AnyRidge Kit

I. AnyRidge Abutment Selection Guide Kit

Ref.C

KANASG3000

For the best selection of abutments.

- Colors indicate different cuff heights (Yellow : 2mm, White : 3mm, Pink : 4mm, Red : 5mm).
- Store 2 pieces in each container.
- Autoclavable to sterilize.

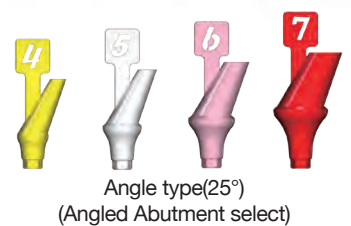
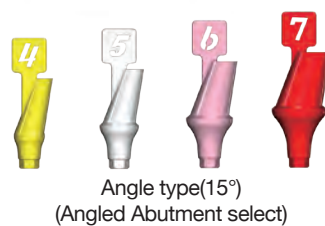
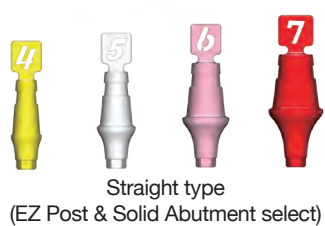
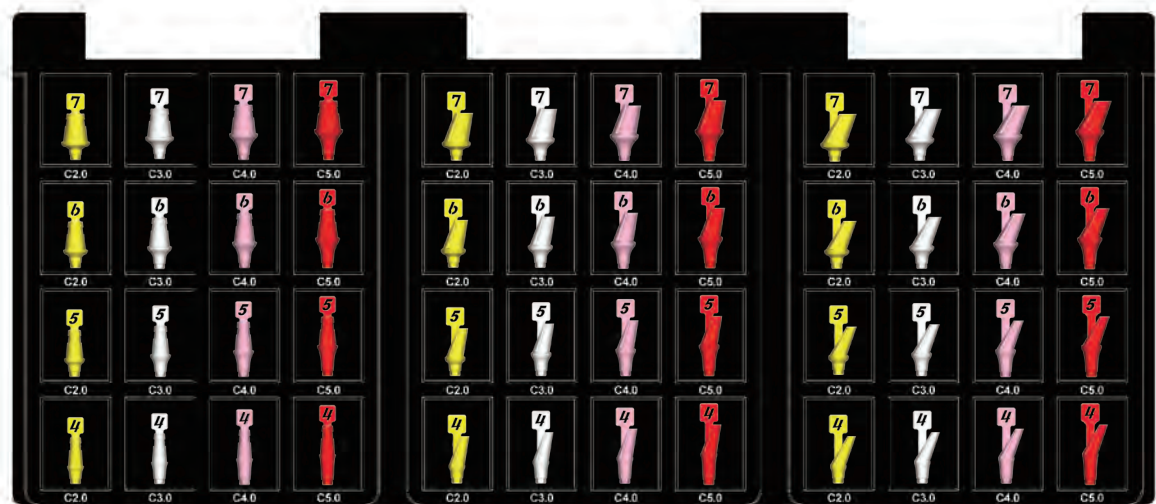

➔ Surgical Kit Components

Lance Drill

- Useful to make an indentation on cortical bone to confirm the exact drilling location.

Diameter	Type	Ref.C
Ø2.0	Long	MGD100L

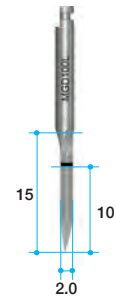

Marking Drill

- Each drill has calibrations from 7.0 to 18.0mm. (TANSDF4815, TANSDF5415, TANSDF5915 have calibrations up to 15.0mm)
- Easy to recognize by dual marking systems. (Groove and laser marking)

Diameter	Length (mm)	Ref.C
Ø2.0	18	TANTDF2018
Ø2.5		SD2518S
Ø2.8		SD2818S
Ø3.3		TANSDF3318
Ø3.8		TANSDF3818
Ø4.3	TANSDF4318	15
Ø4.8	TANSDF4815	
Ø5.4	TANSDF5415	
Ø5.9	TANSDF5915	



Stopper Drill

Diameter	Length (mm)	Ref.C
Ø2.0	7	TANTDF2007
	8.5	TANTDF2008
	10	TANTDF2010
	11.5	TANTDF2011
Ø2.8	7	SD2807M
	8.5	SD2808M
	10	SD2810M
	11.5	SD2811M
Ø3.3	7	TANSDF3307
	8.5	TANSDF3308
	10	TANSDF3310
	11.5	TANSDF3311
Ø3.8	7	TANSDF3807
	8.5	TANSDF3808
	10	TANSDF3810
	11.5	TANSDF3811
Ø4.3	7	TANSDF4307
	8.5	TANSDF4308
	10	TANSDF4310
	11.5	TANSDF4311
Ø4.8	7	TANSDF4807
	8.5	TANSDF4808
	10	TANSDF4810
	11.5	TANSDF4811

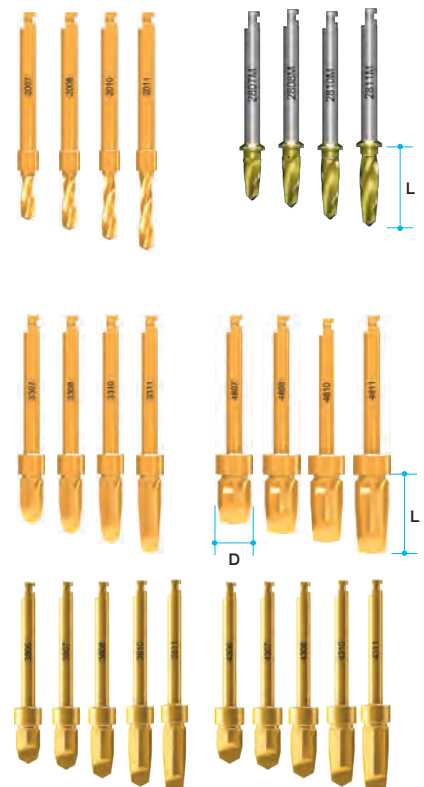

➔ Surgical Kit Components (Continued)

Point Trephine Bur

Diameter	Ref.C
Ø5.0 (In.Ø4.0)	SPTB4050



Trephine Bur

- Minimizes the drilling steps needed, especially for wider fixtures.
- Helpful for collecting autogenous bone.
- Useful for removing failed and fractured fixtures.
- Depth markings are 7, 8.5, 10, 11.5, 13mm, same depths as fixtures. (No Y dimension so markings are actual length).
- Markings on the drill shaft represent the inside / outside diameter of Trephine Burs.

Diameter	Type	Ref.C
Ø3.5 (in Ø2.5)	Short (32mm)	TANTBL2535
Ø5.0 (in Ø4.0)		TANTBL4050
Ø6.0 (in Ø5.0)		*TANTBL5060
Ø7.0 (in Ø6.0)		*TANTBL6070
Ø3.5 (in Ø2.5)	Long (38mm)	*TANTBE2535
Ø5.0 (in Ø4.0)		*TANTBE4050
Ø6.0 (in Ø5.0)		*TANTBE5060
Ø7.0 (in Ø6.0)		*TANTBE6070

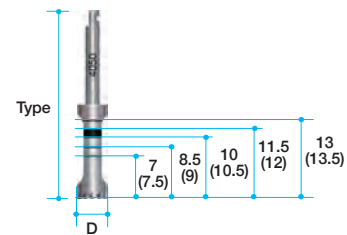

(*) Separate sales item.

3.5, 5.0 Trephine Bur are included in Surgical kit.

Cortical Bone Drill

- Removes cortical bone and enlarges osteotomy socket especially at hard bone.
- Similar function with countersink drill of other systems.
- Each drill has two steps of diameter for convenience.

Diameter	Ref.C
Ø3.5	TANCDL3500
Ø4.0~ Ø5.5	TANCDL4055
Ø6.0~ Ø8.0	TANCDL6080

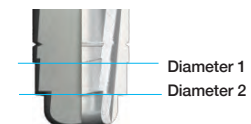

Handpiece Connector

- Delivers torque for the placement of a fixture with a handpiece.
- Easy and secure pick-up and delivery.
- Used to place an implant without a mount.
- Marks on the shaft can indicate the position of fixture platform, especially in flapless surgery.

Length (mm)	Type	Ref.C
5	*Ultra short	TANHCU
10	Short	TANHCS
15	Long	TANHCL
10	Short (MiNi)	HCS17
15	Long (MiNi)	HCL17

(*) Separate sales item.

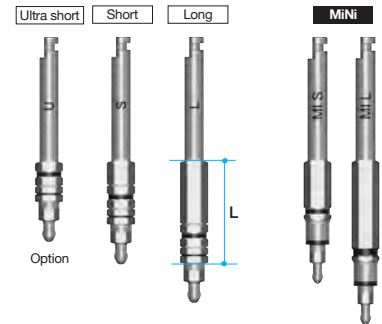

Ratchet Connector

- Delivers torque for the placement or removal of a fixture with a Ratchet Wrench.
- Secure a Ratchet Extension or Torque Wrench to a fixture before exerting force.
- Too much torque force can result a damage to the hex of a fixture.
- Marks on the shaft can indicate the position of fixture platform, especially for flapless surgery.

Length (mm)	Type	Ref.C
6	*Ultra short	TANREU
10	Short	TANRES
15	Long	TANREL
15	Short (MiNi)	RCS17
20	Long (MiNi)	RCL17

(*) Separate sales item.

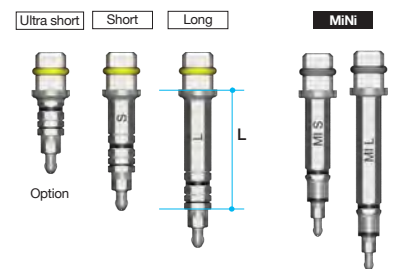

Hand Driver (1.2 Hex)

- Used for all Cover Screws, all Abutment Screws and all Healing Abutments.
- Available in 4 lengths for convenience.
- Hand Driver can be directly inserted into the Torque Wrench without using an adapter.
- Hex tip can withstand 35-45Ncm of torque without distortion.

Length(mm)	Type	Ref.C
5	*Ultra-short	TCMHDU1200
10	Short	TCMHDS1200
15	Long	TCMHDL1200
20	*Extra-long	TCMHDE1200

(*) Separate sales item.



➔ Surgical Kit Components

Abutment Removal Driver

- Used to remove final abutment ; use after removing Abutment Screw.
- Insert straight into the abutment and rotate clockwise.
- Long Abutment Removal Driver is for disconnecting an abutment with a cemented crown.

Length (mm)	Ref.C
17.5	TANMRD18
25.0	*TANMRD25

(*) Separate sales item.



Drill Extension

- Extends drills & other handpiece tools.
- No more than 35Ncm torque : Can be distorted when too much force is applied.

Ref.C
MDE150



Direction Indicator

- Confirms drilling direction and location during drilling.
- Checks drilling position.

Length (mm)	Ref.C
Ø2.0 / Ø2.8	MDI100
Ø3.2 / Ø4.7	MDI3348

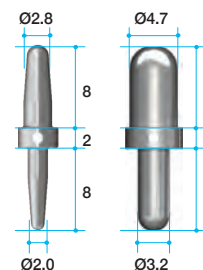

Path Finder

- After placing a fixture, a Path Finder can be connected to guide parallel for the next implant.
- Gingival depth can be measured with the grooves especially for flapless surgeries.

Length (mm)	Ref.C
10	TANPF3580

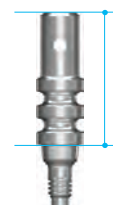

Torque Wrench & Adapter

- Torque Wrench has torque options from 15Ncm to 45Ncm and is used for the placement of an implant and final tightening of the Abutment Screw.

Type	Ref.C
Torque Wrench	MTW300AT
*Torque Wrench Adapter(Handpiece)	TTAI100
Torque Wrench Adapter(Ratchet)	TTAR100

(*) Separate sales item.

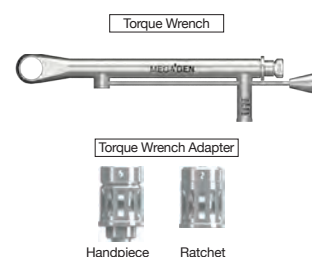

III. AnyRidge Prosthetic Kit

Ref.C
KANPK3000

A kit with all kinds of driver that are needed for prosthetics.

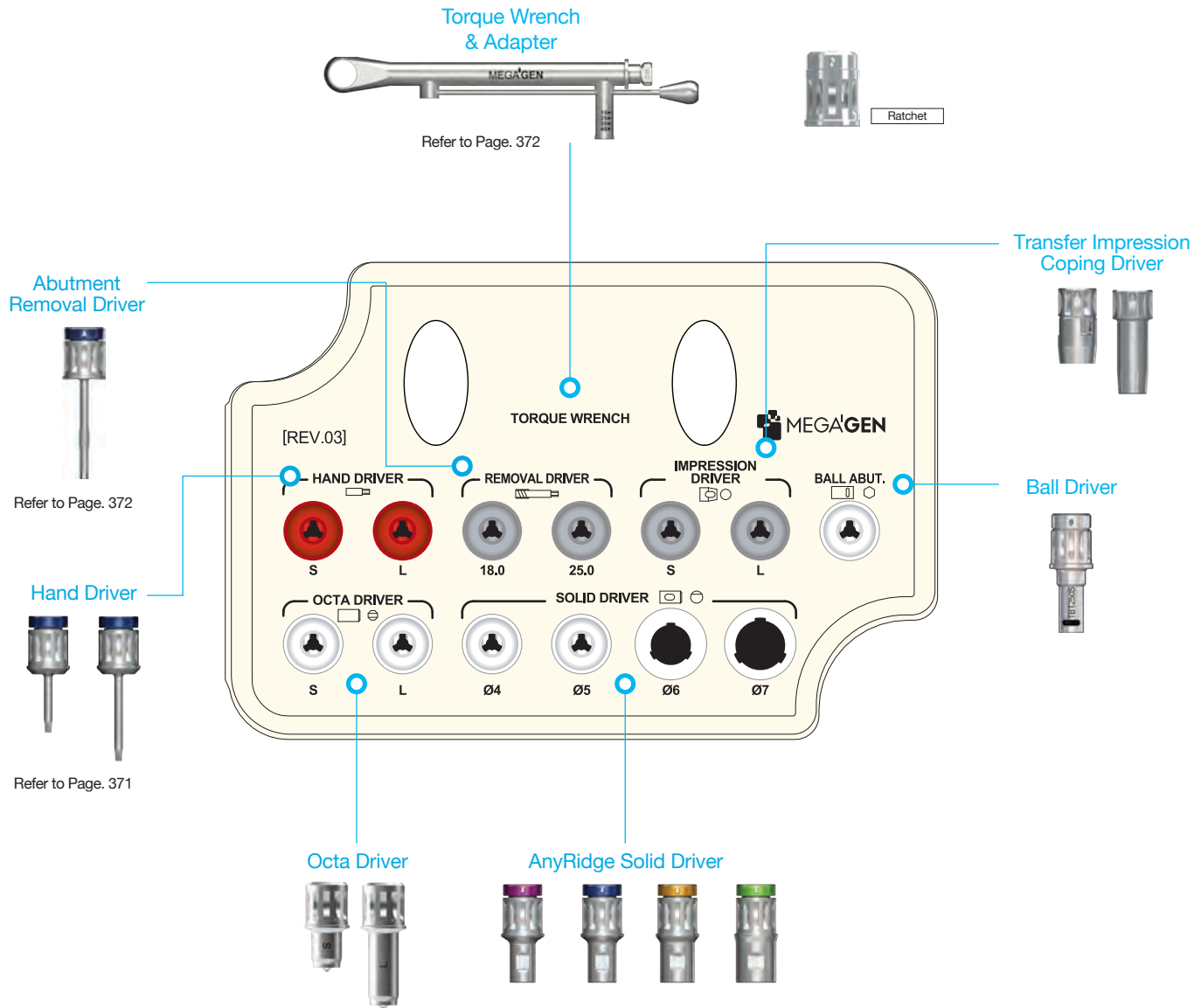

➔ Prosthetic Kit Components

Solid Driver

- For the delivery of Solid Abutments.
- Color coded for different profile diameters. (Ø4-magenta, Ø5-blue, Ø6-yellow, Ø7-green)
- Two different heights. (8.5 / 13.5mm)
- Directly connectable to Torque Wrench.

Solid Abutment Profile Diameter	Length(mm)	Ref.C
Ø4	8.5	TANSDS400
	13.5	*TANSDL400
Ø5	8.5	TANSDS500
	13.5	*TANSDL500
Ø6	8.5	TANSDS600
	13.5	*TANSDL600
Ø7	8.5	TANSDS700
	13.5	*TANSDL700



(*) Separate sales item.

Octa Driver

- For seating of the Octa Abutment into the fixture.
- Can also be connected to Torque Wrench.

Length (mm)	Ref.C
7	MOD300S
13	MOD300L



Ball Driver

- For seating of the Ball Abutment into the fixture.
- Can connect to a Handpiece, Ratchet or Torque Wrench.
- Available in long and short.

Type	Ref.c
*Handpiece Connector(Short)	TBH250S
*Handpiece Connector(Long)	TBH250L
*Ratchet Connector(Short)	TBR250S
*Ratchet Connector(Long)	TBR250L
Toque Driver(Short)	TBT250S
*Toque Driver(Long)	TBT250L

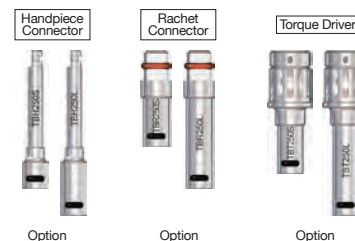

(*) Separate sales item.

Impression Coping Driver (Transfer)

- For transfer type of Impression Coping.
- Works with friction only.
- Small but powerful grip.

Type	Ref.C
For Two piece impression Coping	TCMID
For One piece impression Coping	TCMIDE

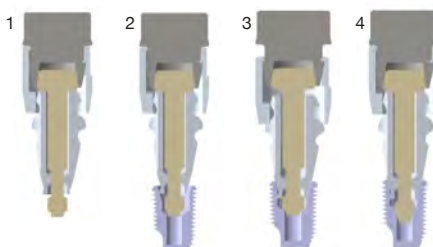

1. Connect Impression Coping and Impression Driver together
2. Adjust Connection with a Fixture by turning a Holder clockwise.
3. Push the Holder and put the Impression Coping into the Fixture.
4. Turn the Driver clockwise to ensure connection of the Impression Coping and Fixture.

IV. AnyRidge Bone Profiler Kit

Ref.C

KARBP3000

Removes the overhanged bone around a fixture to allow adequate seating of a Healing Abutment or a Prosthetic Abutment.

- Place a Guide Pin into a fixture and choose a Bone Profiler which fits with the situation.
- Four different sizes of bone profiler and four guide pins are included in the kit.

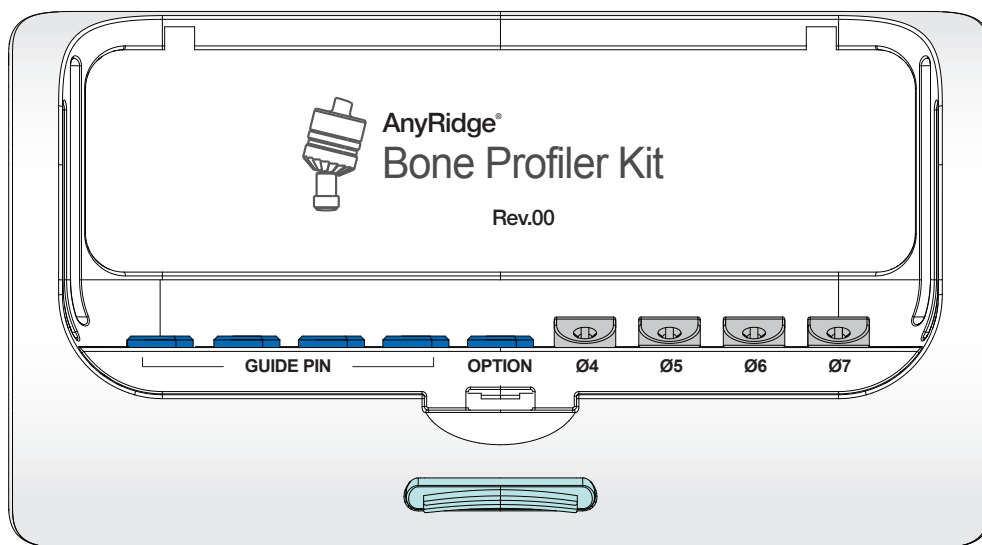

Bone Profiler

- Guide Pin(TANPGF3305) included.

- Each bone profiler can be purchased separately for refill.
- Each package includes a bone profiler and a guide pin.

Profile Diameter	Length (mm)	Ref.C
Ø4	13	TANBPL40G
Ø5		TANBPL50G
Ø6	8	TANBPS60G
Ø7		TANBPS70G

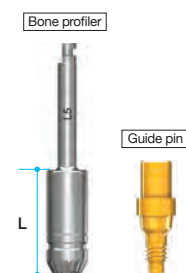

V. Optional components

- not included in the surgical kit
- can be purchased separately and placed into the 'option' spaces provided in the surgical kit

Right Angle Driver Tip

- Used for all Cover Screws, all abutment screws and all Healing Abutments.
- Hex tip can withstand 35-45Ncm of torque without distorting.

Length(mm)	Type	Ref.C
4	Ultra-short	MDR120SS
10	Short	MDR120S
15	Long	MDR120L
20	Extra Long	MDR120EL

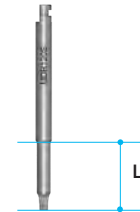

Lindermann Drill

- Cross cut on the drill.
- Can correct the path during drilling.

Diameter(mm)	Ref.C
2	TEEL200M

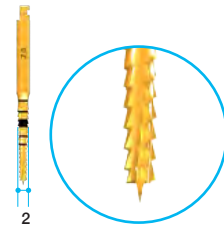

Insert Driver

- Used for all Cover Screws, all abutment screws and all Healing Abutments.
- Hex tip can withstand 35-45Ncm of torque without distorting.

Length(mm)	Type	Ref.C
10	Short	MID120S
15	Long	MID120L

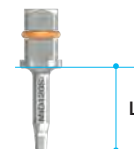

Hand Tap

- Useful when the internal screw of a fixture is damaged.
- Retapping damaged threads.
- Need to be patient and force-controlled.

Type	Ref.C
M1.8	THT180L



Multi-unit Driver (2.0 Hex) (For Multi-unit Abutment)

- For the seating & tightening of multi-unit Abutment (Straight type)

Length(mm)	Type	Ref.C
10	Short	TCMMUDS20
15	Long	TCMMUDL20

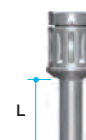

Flattening Drill

- In the case of irregular bone, stopper drill can be drilled in precise depth by flattening the bone.
- Flattening Lance and Housing are connected together. Two types of Housing diameters (Ø5.0 & Ø6.0) are composed in accordance with the size of final drill diameter.
- Ø5.0 = Stopper Drill Ø2.0~ Ø4.3
Ø6.0 = Stopper Drill Ø4.8~ Ø5.4
- Formation of boundary through housing will guide the next drilling location of fixture.

Diameter	Length (mm)	Ref.C
Ø5.0 / Ø2.0	3.5	FD5020
Ø6.0 / Ø2.0		FD6020

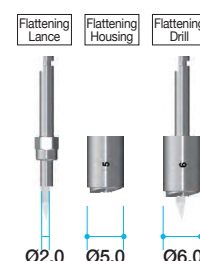

Manual Inserter

- Specially designed for manual placement of AnyRidge fixture.
- Especially useful at immediate implant placement on maxillary anterior.
- The tip has same structure with the hand-piece connector.

Ref.C
TANMI

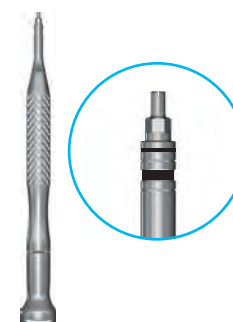

Reamer Drill & Center Pin

- Removes inner lip of the cast after casting Burn-out Cylinders of Solid Abutment.
- Center Pin have 4 different diameters according to the profile diameter of Solid Abutments.

Diameter	Type	Ref.C
Ø10.0	Reamer Drill	TANRD
Ø4.0	Center Pin	TANRDJ40
Ø5.0		TANRDJ50
Ø6.0		TANRDJ60
Ø7.0		TANRDJ70



Trephine Bur Stopper

- Controls the depth of trephination with a Stopper placed into the Trephine.
- Especially useful in cases with limited available bone from important anatomy.

Length (mm)	Ref.C
7.0	TANTSF2307
8.5	TANTSF2308
10.0	TANTSF2310
11.5	TANTSF2311

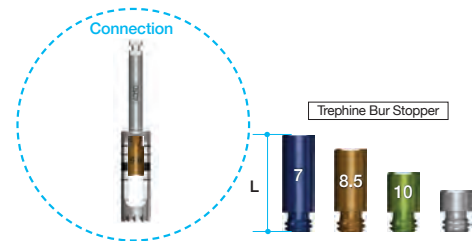

Bottom Drill

- It removes remaining bone in osteotomy socket after trephine drilling.
- It imprints the sizes of fixtures, for example 7, 8.5, 10, 11.5 and 13mm, by laser marker.

Diameter	Type	Ref.C
Ø3.3	Short (32mm)	TCMBDS33
Ø3.8		TCMBDS38
Ø4.8		TCMBDS48
Ø5.8		TCMBDS58
Ø6.8		TCMBDS68
Ø3.3	Long (38mm)	TCMBDL33
Ø3.8		TCMBDL38
Ø4.8		TCMBDL48
Ø5.8		TCMBDL58
Ø6.8		TCMBDL68

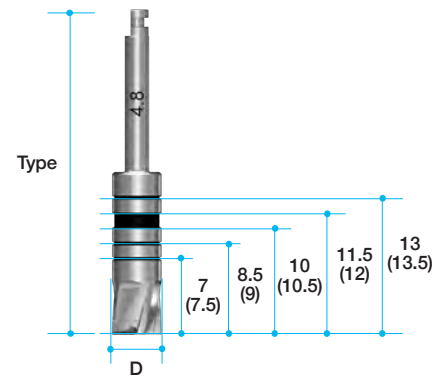

Ratchet Wrench

- Used to exert more force than handpiece.
- No bearing system : No breakage and corrosion problems.
- Attaches to Ratchet Extension.
- Arrow laser marking indicates direction of force.

Ref.C
MRW040S



R2GATE Surgical KIT

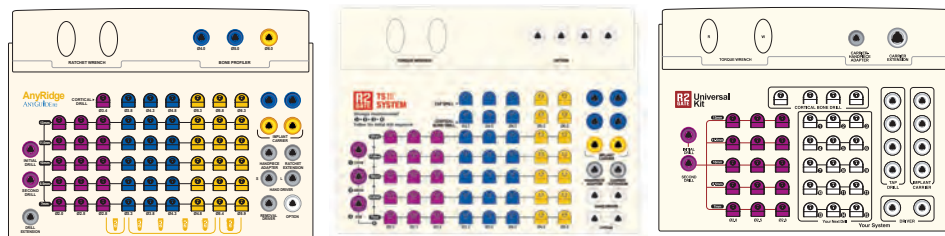

104 R2GATE FULL Surgical KIT

104 I. AnyRidge System

109 R2GATE Narrow KIT

111 R2GATE Anchor KIT

R2GATE® Full Surgical KIT

I. R2GATE Full Surgical Kit for AnyRidge System

- If you only use a specific system, corresponding system's full kit can be provided.
- R2GATE full surgical kit is composed with all of drills and components that are needed for the Digital Guided Surgery which uses R2GATE Guide™ after R2GATE™ diagnosis. It helps to actualize minimally invasive surgery and makes exact clinical result as the diagnosis.

Ref.C
KAGIN3000

Cortical Bone Drill



In type I or II bone, crestal bone is partly reduced to lower the pressure against the fixture during placement.

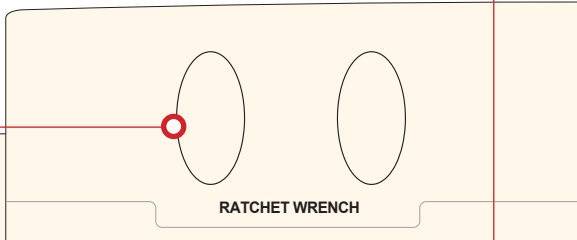

Initial Drill

Initial Drill



Second Drill



Drilling to make the initial drill path

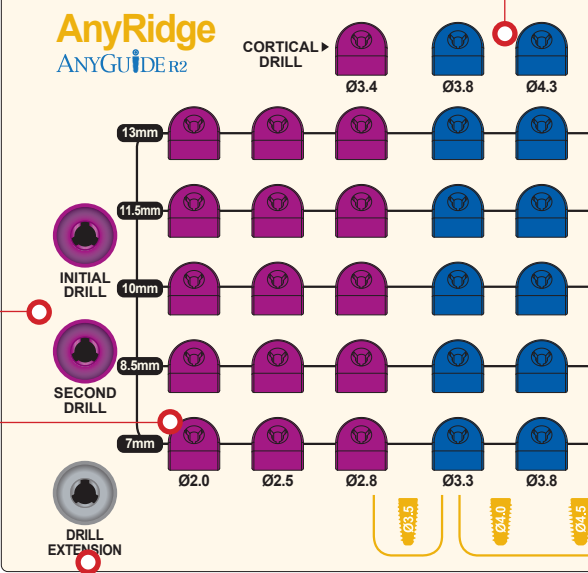

Guide Stop Drill

Drill diameter : Ø2.0 ~ Ø5.9
Drill Length : 7.0 ~ 13.0mm



Guide length : 13.5mm
Drilling length : 7.0 ~ 13.0mm

Drill Extension



Bone Profiler



This is used to minimize the interference of the crestal bone when connecting ZrGEN Abutment, [Used before placing the fixture / Recommended RPM 600 ~1000]

Implant Carrier

: Handpiece type
: Ratchet type

▶ R – AnyRidge Regular (ø3.5 ~ø4.5)



▶ W – AnyRidge Wide (ø5.0 ~ ø6.0)



Ø4.0 Ø5.0 Ø6.0

BONE PROFILER

Ø4.8 Ø5.3 Ø5.8 Ø6.3

IMPLANT CARRIER

HANDPIECE ADAPTER **RATCHET EXTENSION**

S **L**

HAND DRIVER

REMOVAL DRIVER **OPTION**

Ø4.3 Ø4.8 Ø5.4 Ø5.9

Ø5.0 Ø5.5 Ø6.0



Hand Driver

: 1.2 hex driver (Short)
: 1.2 hex driver (Long)
: Abutment Remover Driver



Carrier-Handpiece Adapter



Carrier Extension



➔ Components for R2GATE Full Surgical Kit (Continued)

- If you only use a specific system, corresponding system's full kit can be provided.
- R2GATE full surgical kit is composed with all of drills and components that are needed for the Digital Guided Surgery which uses R2GATE Guide™ after R2GATE™ diagnosis. It helps to actualize minimally invasive surgery and makes exact clinical result as the diagnosis.

Initial Drill

- Use the initial drill in order to mark the drilling position on the bone. Start drilling slowly, when drill guide part is fully contacted with drilling core of R2GATE Guide™.
- Recommended drilling speed range is 300 ~ 800 RPM with copious irrigation.

Diameter	Guide Diameter	Length(mm)	Ref.C
Ø2.6	Ø5.0	1.0	R2ID2601

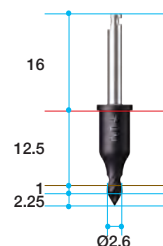

Second Drill

- This unique step-drill(from Ø2.0 to Ø4.6) is used to flare out the upper cortical bone of the osteotomy.
- It helps not only the rest drilling procedure but abutment connection. In case of hard bone, if the 2nd drilling will be disturbed by thick cortical bone. Stop the drilling and try it after final drilling procedure.

Diameter	Guide Diameter	Length(mm)	Ref.C
Ø2.5	Ø5.0	5.0	R2SD2505

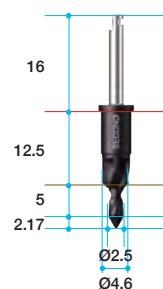

Stopper Drill

- Universal drills consist of Ø2.0, Ø2.5, Ø2.8 diameter to enlarge the osteotomy gradually.
- The length of drill are designed as 7.0, 8.5, 10, 11.5, 13mm for most common length of implant system.
- Recommended drilling speed range is 500 ~ 800 RPM with copious irrigation.

Diameter	Guide Diameter	Length(mm)	Ref.C
Ø2.0	Ø5.0	6.5	AGSD2007
		8.0	AGSD2008
		9.5	AGSD2010
		11.0	AGSD2011
		12.5	AGSD2013
Ø2.5		6.5	AGSD2507
		8.0	AGSD2508
		9.5	AGSD2510
		11.0	AGSD2511
		12.5	AGSD2513
Ø2.8		6.5	AGSD2807
		8.0	AGSD2808
		9.5	AGSD2810
		11.0	AGSD2811
		12.5	AGSD2813

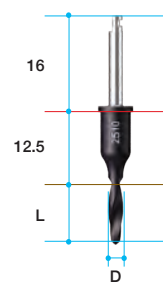

Bone Profiler

- Recommended drilling speed is 300 ~ 800 RPM.

Diameter	Guide Diameter	Ref.C
Ø4.0	Ø5.0	AGBP40
Ø5.0		AGBP50
Ø6.0		AGBP60



Stopper Drill[AR]

• Recommended drilling speed is 300 ~ 800 RPM.

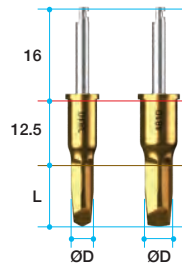

Diameter	Guide Diameter	Length(mm)	Ref.C	Diameter	Guide Diameter	Length(mm)	Ref.C
Ø3.3	Ø5.0	6.5	ARSD3307	Ø4.8	Ø6.5	6.5	ARSD4807
		8.0	ARSD3308			8.0	ARSD4808
		9.5	ARSD3310			9.5	ARSD4810
		11.0	ARSD3311			11.0	ARSD4811
		12.5	ARSD3313			12.5	ARSD4813
Ø3.8	Ø5.0	6.5	ARSD3807	Ø5.4	Ø6.5	6.5	ARSD5407
		8.0	ARSD3808			8.0	ARSD5408
		9.5	ARSD3810			9.5	ARSD5410
		11.0	ARSD3811			11.0	ARSD5411
Ø4.3	Ø5.0	12.5	ARSD3813	Ø5.9	Ø6.5	12.5	ARSD5413
		6.5	ARSD4307			6.5	ARSD5908
		8.0	ARSD4308			8.0	ARSD5907
		9.5	ARSD4310			9.5	ARSD5910
		11.0	ARSD4311			11.0	ARSD5911
		12.5	ARSD4313			12.5	ARSD5913

Cortical Bone Drill[AR]

• Recommended drilling speed : 300 ~ 800 RPM

Diameter	Guide Diameter	Length(mm)	Ref.C
Ø3.4	Ø5.0	5.0	R2CD3405
Ø3.8			R2CD3805
Ø4.3			R2CD4305
Ø4.8			R2CD4805
Ø5.3	Ø6.5	5.0	R2CD5305
Ø5.8			R2CD5805
Ø6.3			R2CD6305

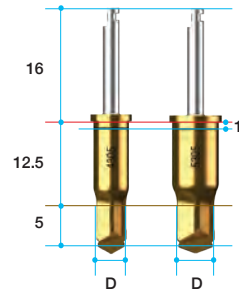

Implant Carrier[AR]

• The purpose of tab drills in the universal kit system is insertion test. some of implant are required this procedure before final fixture insertion. choose the one-step under size of tab to protect from enlargement of osteotomy.
 • Recommended insertion torque and speed is 45 ~ 50Ncm, under 40 RPM.

Connection	Guide Diameter	Type	Ref.C
2.3 Hex	Ø5.0	Ratchet	ICRH2324
	Ø6.5		ICWH2324
	Ø5.0	Handpiece	ICRH2324H
	Ø6.5		ICWH2324H

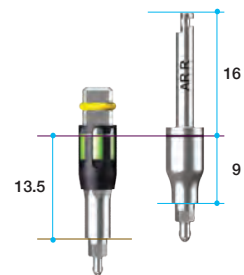

➔ Components for R2GATE Full Surgical Kit (Continued)

Carrier-Handpiece Adapter

- Useful to use the handpiece for the implant placement following initial delivery of a fixture with a fixture carrier.

Diameter	Ref.C
5.0	AGHA



Carrier Extension

- To extend the length of implant carrier.

Diameter	Ref.C
4.0	MRE400S



Drill Extension

- No more than 35Ncm torque : May distorted when excessive force is applied.
- Extends drills & other handpiece instruments.

Ref.C
MDE150



Hand Driver (1.2 Hex)

- Used for all Cover Screws, Abutment Screws, and Healing Abutments.
- Available in 4 lengths for added convenience.
- Hand Driver can be directly inserted into the Torque Wrench without using an adaptor.
- Hex tip can with stand 35-45Ncm of torque without distorting.

Length(mm)	Type	Ref.C
5.0	*Ultra-short	TCMHDU1200
10	Short	TCMHDS1200
15	Long	TCMHDL1200
20	*Extra-long	TCMHDE1200



(*) Separate sales item.

Ratchet Wrench

- Used to exert more force than the Handpiece.
- No bearing system : No breakage and no corrosion problems.
- Arrow laser marking indicates direction of force.

Ref.C
MRW040S



R2GATE Narrow Kit

Ref.C

KAGNS3000

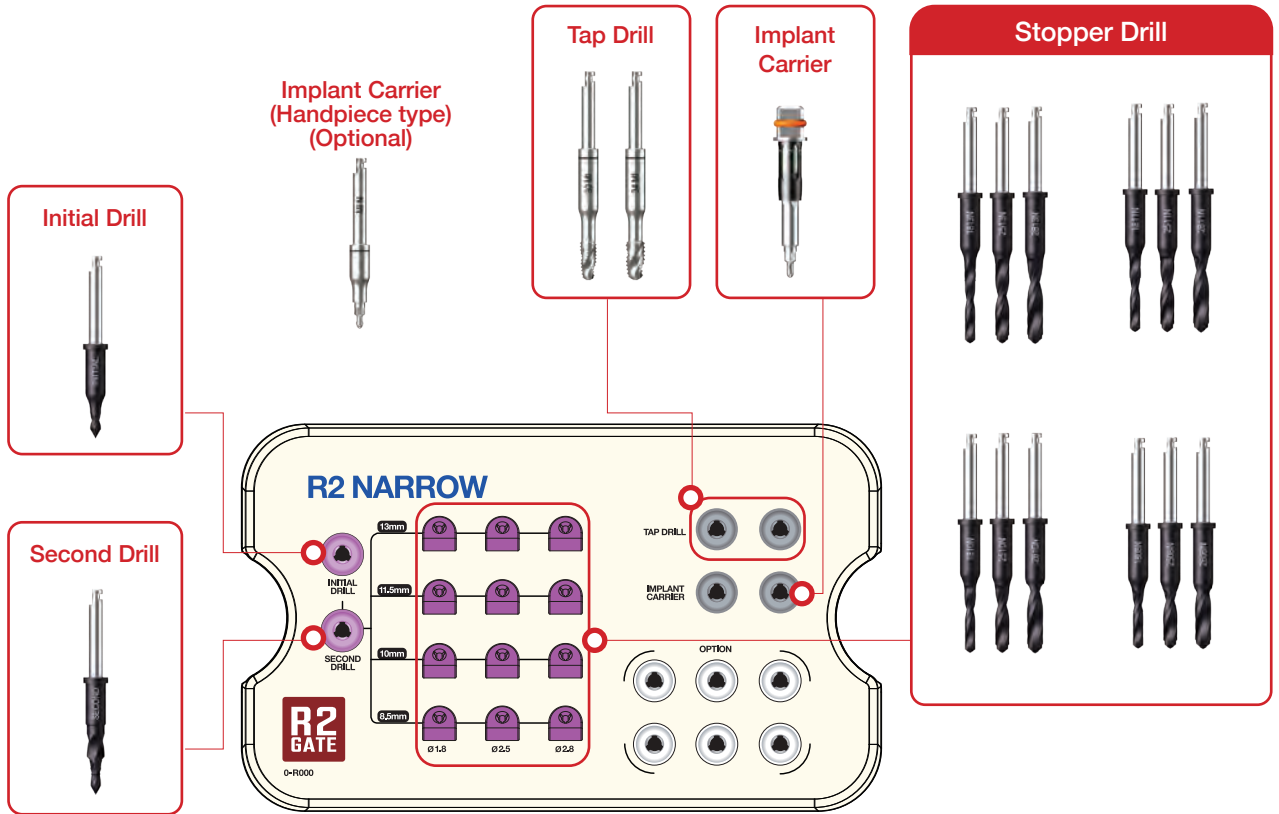

When do we use R2GATE Narrow Kit?

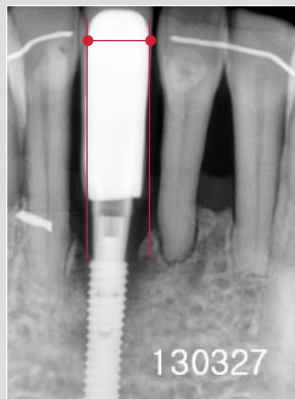

[Mandible single case]
When Ø5.0 stent cannot be fabricated due to narrow distance between the teeth.



[Mandible multiple case]
When fixture cannot be placed near adjacent teeth due to large stent core on regular stent.

Regular VS Narrow Stent Guide Core

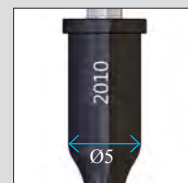

Regular Stent
[Guide Core Ø5]



Narrow Stent
[Guide Core Ø3.5]

➔ Components of R2GATE Narrow Kit



Initial Drill

- Use the initial drill in order to mark the drilling position on the bone. Start drilling slowly, when drill guide part is fully contacted with drilling core of R2GATE Guide™.
- Recommended drilling speed range is 300 ~ 800 RPM with copious irrigation.

Diameter	Guide Diameter	Length(mm)	Ref.C
Ø1.9	Ø3.5	1.0	R2ID1901N

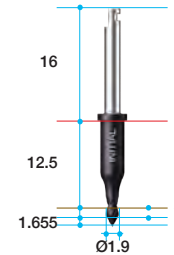

Second Drill

- This unique step-drill(from Ø2.0 to Ø4.6) is used to flare out the upper cortical bone of the osseotomy.
- It helps not only the rest drilling procedure but abut-ment connection. In case of hard bone, if the 2nd drilling will be disturbed by thick cortical bone. Stop the drilling and try it after final drilling procedure.

Diameter	Guide Diameter	Length(mm)	Ref.C
Ø1.8	Ø3.5	5.0	R2SD1805N



Stopper Drill

- Universal drills consist of Ø2.0, Ø2.5, Ø2.8 diameter to enlarge the osteotomy gradually.
- The length of drill are designed as 7.0, 8.5, 10, 11.5, 13mm for most common length of implant system.
- Recommended drilling speed range is 500 ~ 800 RPM with copious irrigation.

Diameter	Guide Diameter	Length(mm)	Ref.C
Ø1.8	Ø3.5	8.0	R2SD1808N
		9.5	R2SD1810N
		11.0	R2SD1811N
		12.5	R2SD1813N
Ø2.5	Ø3.5	8.0	R2SD2508N
		9.5	R2SD2510N
		11.0	R2SD2511N
		12.5	R2SD2513N
Ø2.8	Ø3.5	8.0	R2SD2808N
		9.5	R2SD2810N
		11.0	R2SD2811N
		12.5	R2SD2813N



Tap Drill

- The purpose of tap drills in the universal kit system is insertion test.
- Recommended insertion torque and speed is 45 ~ 50Ncm, under 40 RPM.

Diameter	Guide Diameter	Length(mm)	Ref.C
Ø3.0	Ø3.5	8.0	R2TD30MI
Ø3.4			R2TD34MI

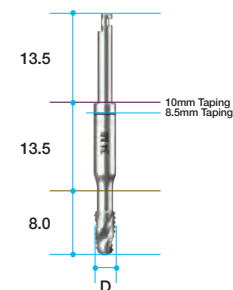

Implant Carrier

- To pick up the fixture from the ampule and insert it to the osseotomy. Then turn it to clock-wise direction 2~3 times manually.
- When it gets fixation from the osteotomy, connect the handpiece adaptor and use implant motor.
- Recommended insertion torque is 45~50Ncm.

Connection	Guide Diameter	Type	Ref.C
1.7 Hex	Ø3.5	Ratchet	ICNH1722
		Handpiece	ICNH1722H

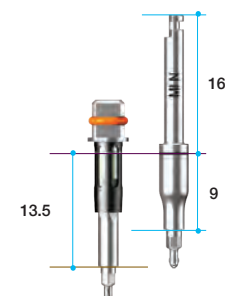

Anchor Kit

For an edentulous case or free end case, R2GATE Guide™ is fixed with Anchor Pins specially designed for stability of the R2GATE Guide™.

System	Ref.C
AnyRidge	KAGAS3000

You can order your own Anchor kit for your favorite implant system

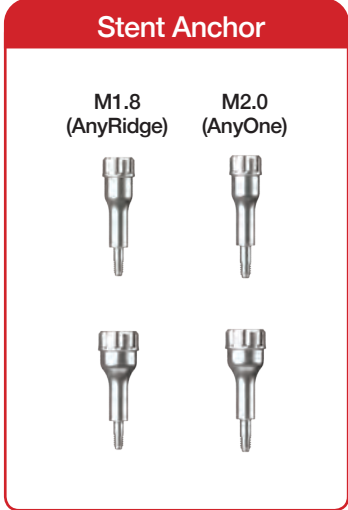
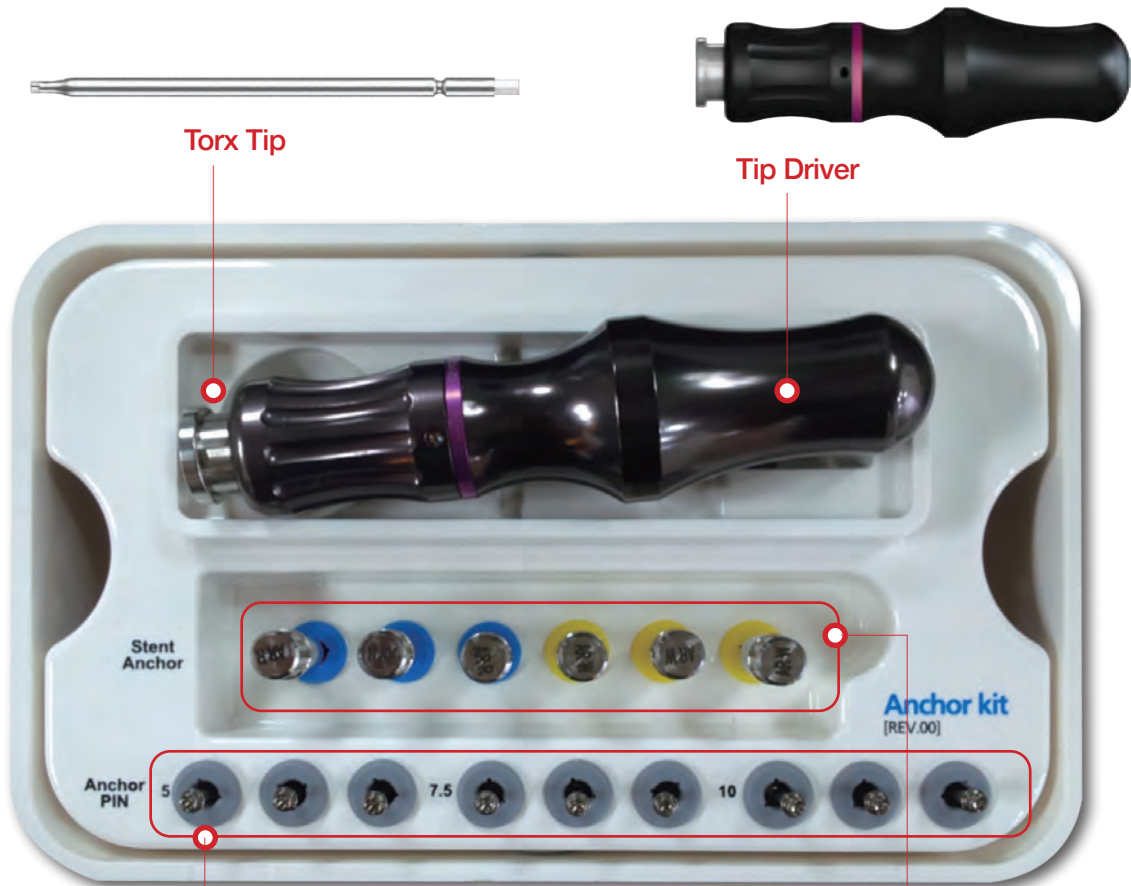

➡ Components for Anchor Kit



Anchor Pin

- Distinguish the length size by the numbers of Line marking
- Connect through Trox Tip

Diameter	Length(mm)	Marking Line	Ref.C
Ø2.0	5.5	1	TCMACP2015
	8.0	2	TCMACP2018
	10.5	3	TCMACP2020

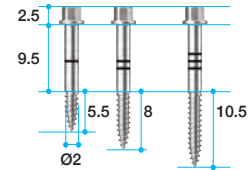

Stent Anchor

- Connect through Hand & Hand Driver

Thread	Guide Diameter	Ref.C
M1.8	Ø5.0	AGSAR18
(AnyRidge)	Ø6.5	AGSAW18

(*) Separate sales item.

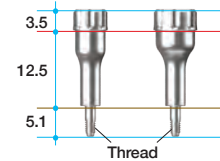

Trox Tip

Length(mm)	Ref.C
80	AGTT80



Tip Driver

Ref.C
TD



►► How to use Anchor Kit?

Case 1.

When it is possible to get stability from neighboring teeth. (No need to use the Anchor kit)



Place the R2GATE Guide™ by placing it onto the neighboring teeth.

Case 2.

When it is hard to get stability from fully edentulous case or neighboring teeth.



1. Fix the R2GATE Guide™ temporarily by asking patient to bite the R2GATE Guide™ using a resin or other tools.
2. Please use the Pin that R2GATE™ program selected, and place that Pin on the Driver Tip.
3. Insert the Pin into the R2GATE Guide™ that the patient is biting, and turn it into clockwise to fix the R2GATE Guide™ to bone.

*Make a hole on the Guide using Ø2.0 Drill if a density of the bone is high. Then, insert the Anchor Pin into the hole.

Case 3.

- When it is necessary to re-implant a fixture after separating the R2GATE Guide™.
- When the stability of the R2GATE Guide™ is weak even though all planned Anchor Pins are used (This is only for the cases with edentulous jaws and implantations of three or more fixtures).

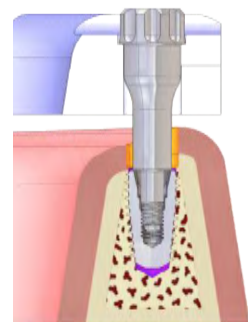
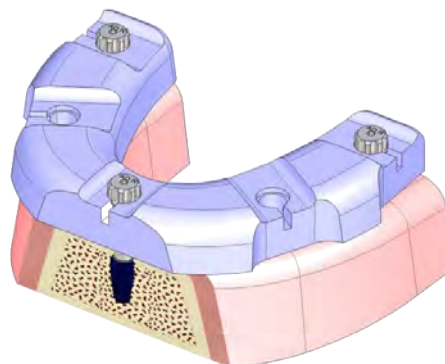

* Cases for re-implant a fixture after failure

1. Check the condition of an implanted fixture after a separation of a R2GATE Guide™. Evulse the fixture when the implantation is considered as a failure for lack of stability or a path is inaccurate.
2. Replace the R2GATE Guide™. Insert the R2GATE Guide™ Anchor to the R2GATE Guide™ Hole of the neighboring fixture, and place the R2GATE Guide™ by turning it into clockwise.

* When it is hard to get stability of the R2GATE Guide™ by an Anchor Pin only

1. When the stability of a fixture by an Anchor Pin only is low, start an implantation from molar areas. Then, connect the R2GATE Guide™ Anchor with an installed fixture to increase stability.

MegaGen Digital Solution

115 Digital Material

116 1. ZrGen

123 2. TiGen

Digital Material

I. ZrGEN®

ZrGEN® is the brand name of MegaGen Titanium Base. ZrGEN provides an aesthetic outcome and simplified dental implant prosthesis. A ZrGEN® crown and monolithic crown connected to a ZrGEN® Abutment provide strong and precise connection with the implant fixture.

Variety of ZrGEN®



ZrGEN Coping

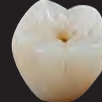

PMMA Provisional Crown



ZrGEN Monolithic



ZrGEN Crown



ZrGEN Bridge



ZrGEN Coping for PFZ

ZrGEN® Sub Structure



ZrGEN



Zirconia customized body



Zirconia Final Crown

ZrGEN®

The strength of ZrGEN® frees you from the chipping of conventional PFM prosthesis. Monolithic zirconia crowns have no metal substructure, ensuring more aesthetic results. ZrGEN® crown and bridge are a superior substitutes for all conventional dental materials.



Tooth shade cuff area



Minimized Ti-connection

Clinical Application

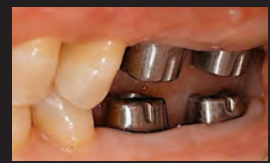

II. TiGEN®

TiGEN® is the brand name of MegaGen Titanium customized abutment. It promises outstanding durability and simplified dental implant prosthesis. Ready-made connection part provides a strong and precise connection with the implant fixture.



➔ ZrGEN® Prosthesis



ZrGEN® Abutment

ZrGEN® Abutment provides a strong and precise connection with the implant fixture. With Zirconia® coping, crown margins can be placed supragingivally since zirconia material matches with the color of natural teeth. Residual cement problems are no longer an issue.

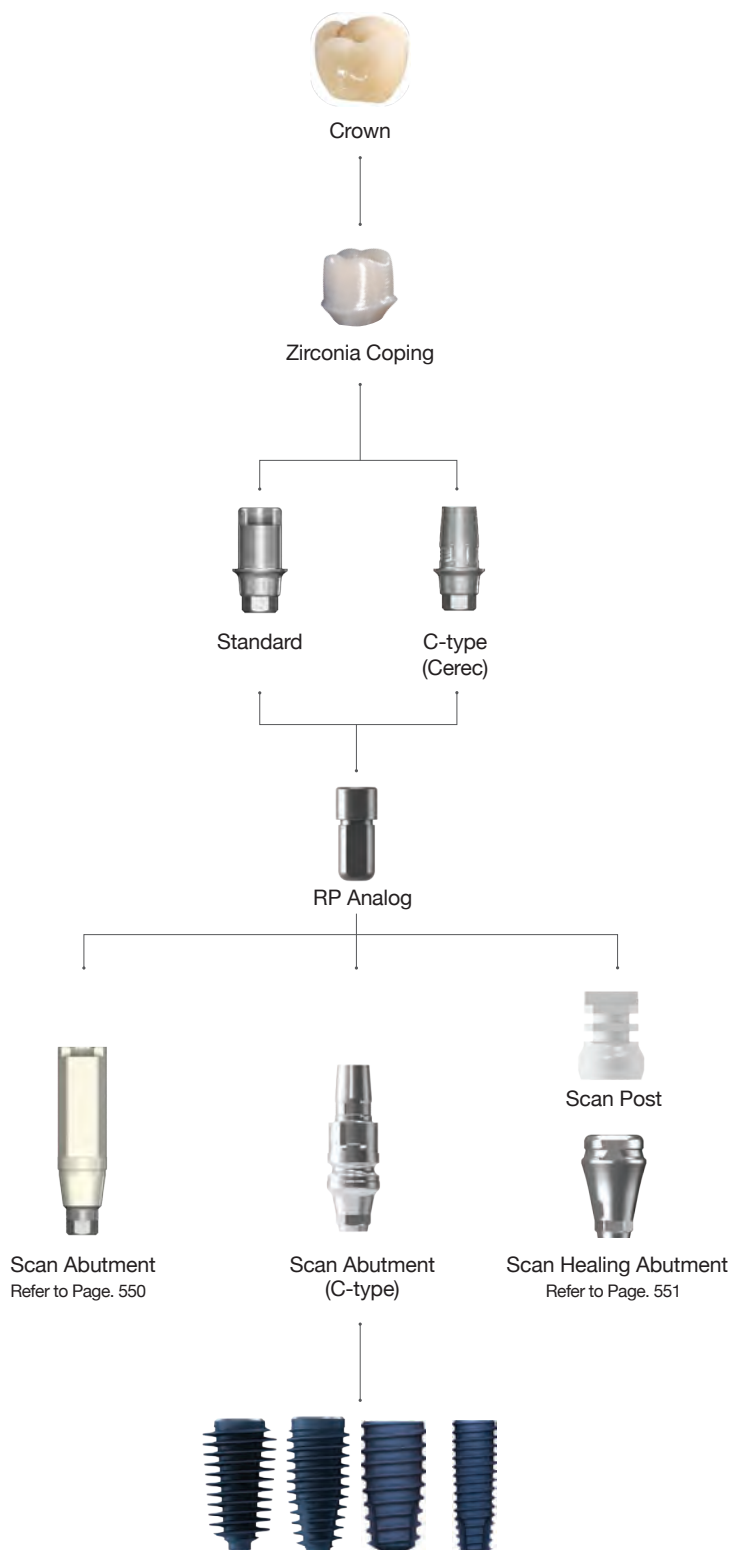

➔ Scan Abutment Option

Scan Abutment

- Abutment Screw included.
- . AnyRidge (AANMSF)
- . MiNi (MIAS14)
- . Octa Level (IRCS200)
- . Multi-unit Abutment (MUAS)

- For Chairside/ Labside
- Included spare Abutment Screw
- Supporting Dental CAD
 - 3 Shape
 - Exocad
 - Dental Wings

System	Profile Diameter	Length (mm)	Type	Ref.C
AnyRidge	Ø4.0	9	-	AANISR4009T
		13	-	AANISR4013T
MiNi	3.5	9	NC	MISS3509T
		13	RC	MISS3513T
Octa Level	Ø4.0	11	-	AOCESC4011T
MUA Level (N-Type)	Ø4.0	13	-	AMUASR4013T

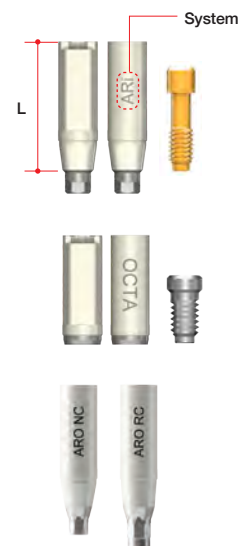

Scan Abutmet (C-type)

- Abutment Screw included.
- . AnyRidge (AANMSF)

- Scan Post for Sirona Cerec users → CEREC
- In in Lab CAD Software, compatible with Xive Library

System	Profile Diameter	Cuff Height	Post Size	Ref.C
AnyRidge	Ø3.9	0.5	Small	ARICSS3405T
		1		ARICSS3410T
		2		ARICSS3420T
	Ø4.3	0.5		ARICSS3805T
		1		ARICSS3810T
		2		ARICSS3820T
	Ø5.5	0.5	Large	ARICSL4505T
		1		ARICSL4510T
		2		ARICSL4520T

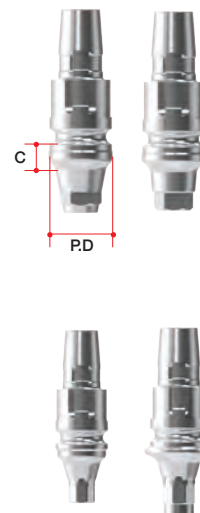

Scan Healing Abutment & Scan Post

- Abutment Screw included.
 - AnyRidge (ARIHS1804/ARIHS1805/ARIHS1807)

- Can get scan data without removing Scan Healing Abutment from Scan Post
- Different colors depend on the cuff size
- Scan healing abutment should be exposed 2.0mm on the surgical site for accurate scanning

- Scan Healing Abutment should be exposed 2.0mm from the surgical site for accurate scanning. Scanning would be much easier if you connect Scan Post when scanning seems difficult due to less exposure of Scan Healing Abutment or other conditions.
- Select Scan Post based on the diameter of Scan Healing Abutment
- Scan Post is a disposable product and sold separately in batch of 10EA. for each package

System	Profile Diameter	Scan Post	Height (mm)	Ref.C
AnyRidge	Ø4.0	SP4007.MTN	4	ARISH4004T
			5	ARISH4005T
			7	ARISH4007T
	Ø5.0	SP5007.MTN	4	ARISH5004T
			5	ARISH5005T
			7	ARISH5007T
	Ø6.0	SP6007.MTN	4	ARISH6004T
			5	ARISH6005T
			7	ARISH6007T
	Ø7.0	SP7007.MTN	4	ARISH7004T
			5	ARISH7005T
			7	ARISH7007T
Ø5.0 (Extra type)	SP5007.MTN	4	ARNSH5004T	
		5	ARNSH5005T	
		7	ARNSH5007T	
Ø6.0 (Extra type)	SP6007.MTN	4	ARNSH6004T	
		5	ARNSH6005T	
		7	ARNSH6007T	

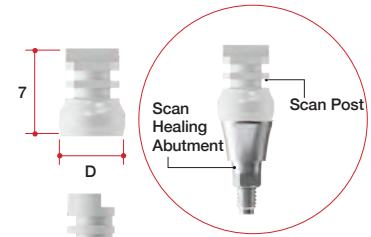

* If Scan Healing Abutment is exposed more than 2.5mm, it may unbalance a fixture and results in fixture failure.

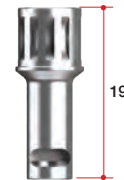
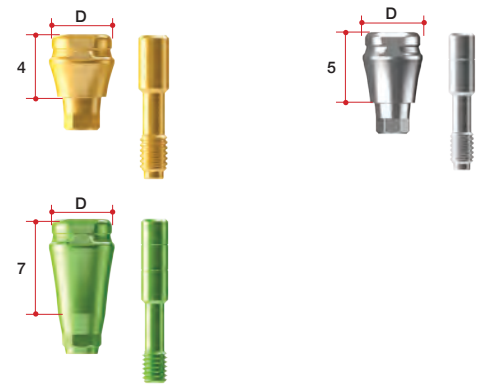

Scan Post Carrier

System	Length	Ref.C
Common	19	SPC16

RP Analog Option

RP Analog

- For Chairside/ Labside
- Included spare Abutment Screw
- Supporting Dental CAD
 - 3 Shape
 - Exocad

System	Profile Diameter	Length (mm)	Type	Ref.C
AnyRidge	Ø4.0	9	-	CANIAR4009
MINi	Ø3.0	9	-	CMIIAN3009
Octa Level	Ø3.8	9	Small	OCTARA4
			Regular	OCTARA5
	Ø5.8		Wide	OCTARA6
MUA Level (N-Type)	Ø4.8	9	-	MUALA

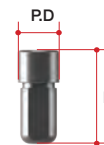

NEW!! ➔ ZrGEN Abutment Option

ZrGEN Abutment

- Abutment Screw included.
- . AnyRidge (AANMSF)
- . MiNi (MIAZ1410)
- . Octa Level(IRCS200)

- Titanium Base
- 1Set(=Abutment 10ea)
 - included spare Abutment Screw
 - MiNi ZrGEN has special ZrGEN Screw
- Supporting DentalCAD
 - 3 Shape
 - Exocad
 - Dental Wing
- Different groove number depend on the post size
 - P=4.5 ▶ groove number : 2ea
 - P=5 ▶ groove number : 3ea
 - P=6 ▶ groove number : 4ea
 - P=8 ▶ groove number : 6ea

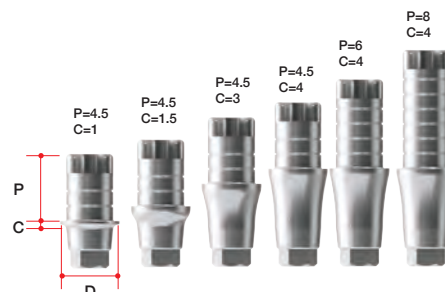

Standard

System	Diameter	Cuff Height	Post Height	Type	Ref.C
AnyRidge	Ø4.0	0.6	4.5	Hex	AANIPR4015.MTN
			6		AANIPR4016.MTN
			8		AANIPR4018.MTN
		1.5	4.5		AANIPR4025.MTN
			6		AANIPR4026.MTN
			8		AANIPR4028.MTN
		3.0	4.5		AANIPR4035.MTN
			6		AANIPR4036.MTN
			8		AANIPR4038.MTN
		4.0	4.5		AANIPR4045.MTN
			6		AANIPR4046.MTN
			8		AANIPR4048.MTN
	Ø4.5	0.6	4.5	Non-Hex	AANIPR4015N.MTN
			6		AANIPR4016N.MTN
			8		AANIPR4018N.MTN
		1.5	4.5		AANIPR4025N.MTN
			6		AANIPR4026N.MTN
			8		AANIPR4028N.MTN
		3.0	4.5		AANIPR4035N.MTN
			6		AANIPR4036N.MTN
			8		AANIPR4038N.MTN
		4.0	4.5		AANIPR4045N.MTN
			6		AANIPR4046N.MTN
			8		AANIPR4048N.MTN
	Ø4.5	0.6	4.5	Hex	AANIPR4515.MTN
			6		AANIPR4516.MTN
			8		AANIPR4518.MTN
		1.5	4.5		AANIPR4525.MTN
			6		AANIPR4526.MTN
			8		AANIPR4528.MTN
		3.0	4.5		AANIPR4535.MTN
			6		AANIPR4536.MTN
			8		AANIPR4538.MTN
		4.0	4.5		AANIPR4545.MTN
			6		AANIPR4546.MTN
			8		AANIPR4548.MTN
Ø4.5	0.6	4.5	Non-Hex	AANIPR4515N.MTN	
		6		AANIPR4516N.MTN	
		8		AANIPR4518N.MTN	
	1.5	4.5		AANIPR4525N.MTN	
		6		AANIPR4526N.MTN	
		8		AANIPR4528N.MTN	
	3.0	4.5		AANIPR4535N.MTN	
		6		AANIPR4536N.MTN	
		8		AANIPR4538N.MTN	
	4.0	4.5		AANIPR4545N.MTN	
		6		AANIPR4546N.MTN	
		8		AANIPR4548N.MTN	

System	Diameter	Cuff Height	Post Height	Type	Ref.C	
MiNi	Ø3.0	0.6	2.5	Hex	MIPN3013.MTN	
			2.5	Non-Hex	MIPN3013N.MTN	
Octa Level	Small	Ø5.0	0.8	5	Octa	AOCEPS5015.MTN
				6		AOCEPS5016.MTN
				8		AOCEPS5018.MTN
			0.8	5	Non-Octa	ANOEPS5015.MTN
				6		ANOEPS5016.MTN
				8		ANOEPS5018.MTN
	Regular	Ø5.5	0.8	5	Octa	AOCEPR5515.MTN
				6		AOCEPR5516.MTN
				8		AOCEPR5518.MTN
			0.8	5	Non-Octa	ANOEP5515.MTN
				6		ANOEP5516.MTN
				8		ANOEP5518.MTN
Wide	Ø6.5	0.8	5	Octa	AOCEPW6515.MTN	
			6		AOCEPW6516.MTN	
			8		AOCEPW6518.MTN	
		0.8	5	Non-Octa	ANOEPW6515.MTN	
			6		ANOEPW6516.MTN	
			8		ANOEPW6518.MTN	
MUA Level	Ø5.5	0.8	5	N-Type (Nobel)	AMUAPR5515N.MTN	
			6		AMUAPR5516N.MTN	
			8		AMUAPR5518N.MTN	



Extra

System	Fixture Core	Diameter	Cuff Height	Post Height	Type	Ref.C
AnyRidge	Core 3.3	Ø4.5	0.6	4.5	Hex	ARZXM4515.MTN
				6		ARZXM4516.MTN
				8		ARZXM4518.MTN
			1.5	4.5		ARZXM4525.MTN
				6		ARZXM4526.MTN
				8		ARZXM4528.MTN
			3.0	4.5		ARZXM4535.MTN
				6		ARZXM4536.MTN
				8		ARZXM4538.MTN
			4.0	4.5		ARZXM4545.MTN
				6		ARZXM4546.MTN
				8		ARZXM4548.MTN
	Core 3.8	Ø5.0	0.6	4.5	Hex	ARZXM503815.MTN
				6		ARZXM503816.MTN
				8		ARZXM503818.MTN
			1.5	4.5		ARZXM503825.MTN
				6		ARZXM503826.MTN
				8		ARZXM503828.MTN
			3.0	4.5		ARZXM503835.MTN
				6		ARZXM503836.MTN
				8		ARZXM503838.MTN
			4.0	4.5		ARZXM503845.MTN
				6		ARZXM503846.MTN
				8		ARZXM503848.MTN
Core 3.8	Ø5.5	0.6	4.5	Hex	ARZXM553815.MTN	
			6		ARZXM553816.MTN	
			8		ARZXM553818.MTN	
		1.5	4.5		ARZXM553825.MTN	
			6		ARZXM553826.MTN	
			8		ARZXM553828.MTN	
		3.0	4.5		ARZXM553835.MTN	
			6		ARZXM553836.MTN	
			8		ARZXM553838.MTN	
		4.0	4.5		ARZXM553845.MTN	
			6		ARZXM553846.MTN	
			8		ARZXM553848.MTN	
Core 3.8	Ø5.0	0.6	4.5	Non -Hex	ARZXM503815N.MTN	
			6		ARZXM503816N.MTN	
			8		ARZXM503818N.MTN	
		1.5	4.5		ARZXM503825N.MTN	
			6		ARZXM503826N.MTN	
			8		ARZXM503828N.MTN	
		3.0	4.5		ARZXM503835N.MTN	
			6		ARZXM503836N.MTN	
			8		ARZXM503838N.MTN	
		4.0	4.5		ARZXM503845N.MTN	
			6		ARZXM503846N.MTN	
			8		ARZXM503848N.MTN	
Core 3.8	Ø5.5	0.6	4.5	Non -Hex	ARZXM553815N.MTN	
			6		ARZXM553816N.MTN	
			8		ARZXM553818N.MTN	
		1.5	4.5		ARZXM553825N.MTN	
			6		ARZXM553826N.MTN	
			8		ARZXM553828N.MTN	
		3.0	4.5		ARZXM553835N.MTN	
			6		ARZXM553836N.MTN	
			8		ARZXM553838N.MTN	
		4.0	4.5		ARZXM553845N.MTN	
			6		ARZXM553846N.MTN	
			8		ARZXM553848N.MTN	

Extra

System	Fixture Core	Diameter	Cuff Height	Post Height	Type	Ref.C		
AnyRidge	Core4.0	Ø5.0	0.6	4.5	Hex	ARZXM5015.MTN		
				6		ARZXM5016.MTN		
				8		ARZXM5018.MTN		
			1.5	4.5		ARZXM5025.MTN		
				6		ARZXM5026.MTN		
				8		ARZXM5028.MTN		
			3.0	4.5		ARZXM5035.MTN		
				6		ARZXM5036.MTN		
				8		ARZXM5038.MTN		
			4.0	4.5	ARZXM5045.MTN			
				6	ARZXM5046.MTN			
				8	ARZXM5048.MTN			
			0.6	Non -Hex	4.5	4.5	ARZXM5015N.MTN	
						6	ARZXM5016N.MTN	
						8	ARZXM5018N.MTN	
					1.5	4.5	ARZXM5025N.MTN	
						6	ARZXM5026N.MTN	
						8	ARZXM5028N.MTN	
					3.0	4.5	ARZXM5035N.MTN	
						6	ARZXM5036N.MTN	
						8	ARZXM5038N.MTN	
			4.0	4.5	ARZXM5045N.MTN			
				6	ARZXM5046N.MTN			
				8	ARZXM5048N.MTN			
		0.6	Non -Hex	0.6	4.5	ARZXM5515.MTN		
					6	ARZXM5516.MTN		
					8	ARZXM5518.MTN		
				1.5	4.5	ARZXM5525.MTN		
					6	ARZXM5526.MTN		
					8	ARZXM5528.MTN		
				3.0	4.5	ARZXM5535.MTN		
					6	ARZXM5536.MTN		
					8	ARZXM5538.MTN		
				4.0	4.5	ARZXM5545.MTN		
					6	ARZXM5546.MTN		
					8	ARZXM5548.MTN		
				0.6	Non -Hex	4.5	4.5	ARZXM5515N.MTN
							6	ARZXM5516N.MTN
							8	ARZXM5518N.MTN
						1.5	4.5	ARZXM5525N.MTN
							6	ARZXM5526N.MTN
							8	ARZXM5528N.MTN
						3.0	4.5	ARZXM5535N.MTN
							6	ARZXM5536N.MTN
							8	ARZXM5538N.MTN
				4.0	4.5	ARZXM5545N.MTN		
					6	ARZXM5546N.MTN		
					8	ARZXM5548N.MTN		
AnyRidge	Core 4.8	Ø5.5	0.6	4.5	Hex	ARZXL5515.MTN		
				6		ARZXL5516 .MTN		
				8		ARZXL5518 .MTN		
			1.5	4.5		ARZXL5525.MTN		
				6		ARZXL5526 .MTN		
				8		ARZXL5528 .MTN		
			3.0	4.5		ARZXL5535.MTN		
				6		ARZXL5536 .MTN		
				8		ARZXL5538 .MTN		
			4.0	4.5	ARZXL5545.MTN			
				6	ARZXL5546 .MTN			
				8	ARZXL5548 .MTN			
			0.6	Non -Hex	4.5	4.5	ARZXL5515N.MTN	
						6	ARZXL5516N.MTN	
						8	ARZXL5518N.MTN	
					1.5	4.5	ARZXL5525N.MTN	
						6	ARZXL5526N.MTN	
						8	ARZXL5528N.MTN	
					3.0	4.5	ARZXL5535N.MTN	
						6	ARZXL5536N.MTN	
						8	ARZXL5538N.MTN	
			4.0	4.5	ARZXL5545N.MTN			
				6	ARZXL5546N.MTN			
				8	ARZXL5548N.MTN			
0.6	Non -Hex	0.6	4.5	ARZXL6015.MTN				
			6	ARZXL6016.MTN				
			8	ARZXL6018.MTN				
		1.5	4.5	ARZXL6025.MTN				
			6	ARZXL6026.MTN				
			8	ARZXL6028.MTN				
		3.0	4.5	ARZXL6035.MTN				
			6	ARZXL6036.MTN				
			8	ARZXL6038.MTN				
		4.0	4.5	ARZXL6045.MTN				
			6	ARZXL6046.MTN				
			8	ARZXL6048.MTN				
		0.6	Non -Hex	4.5	4.5	ARZXL6015N.MTN		
					6	ARZXL6016N.MTN		
					8	ARZXL6018N.MTN		
				1.5	4.5	ARZXL6025N.MTN		
					6	ARZXL6026N.MTN		
					8	ARZXL6028N.MTN		
				3.0	4.5	ARZXL6035N.MTN		
					6	ARZXL6036N.MTN		
					8	ARZXL6038N.MTN		
		4.0	4.5	ARZXL6045N.MTN				
			6	ARZXL6046N.MTN				
			8	ARZXL6048N.MTN				

- ZrGEN Abutment

- Ti-base for Sirona Cerec users → CEREC
- In in Lab CAD Software, compatible with Xive Library

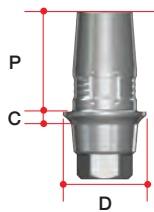

C-Type

System	Diameter	Cuff Height	Post Height	Post Size	Ref.C
AnyRidge	Ø3.9	0.5	4.7	Small	ARCS3405.MTN
		1			ARCS3410.MTN
		2			ARCS3420.MTN
	Ø4.3	0.5			ARCS3805.MTN
		1			ARCS3810.MTN
		2			ARCS3820.MTN
	Ø5.5	0.5		ARCL4505.MTN	
		1		ARCL4510.MTN	
		2		ARCL4520.MTN	

Scan Abutmet (C-type)

- Abutment Screw included.
- AnyRidge (AANMSF)

- Scan Post for Sirona Cerec users → CEREC
- In in Lab CAD Software, compatible with Xive Library

System	Profile Diameter	Cuff Height	Post Size	Ref.C
AnyRidge	Ø3.9	0.5	Small	ARICSS3405T
		1		ARICSS3410T
		2		ARICSS3420T
	Ø4.3	0.5		ARICSS3805T
		1		ARICSS3810T
		2		ARICSS3820T
	Ø5.5	0.5	ARICSL4505T	
		1	ARICSL4510T	
		2	ARICSL4520T	

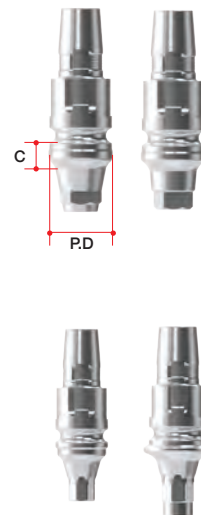

➡ TiGEN Prosthesis

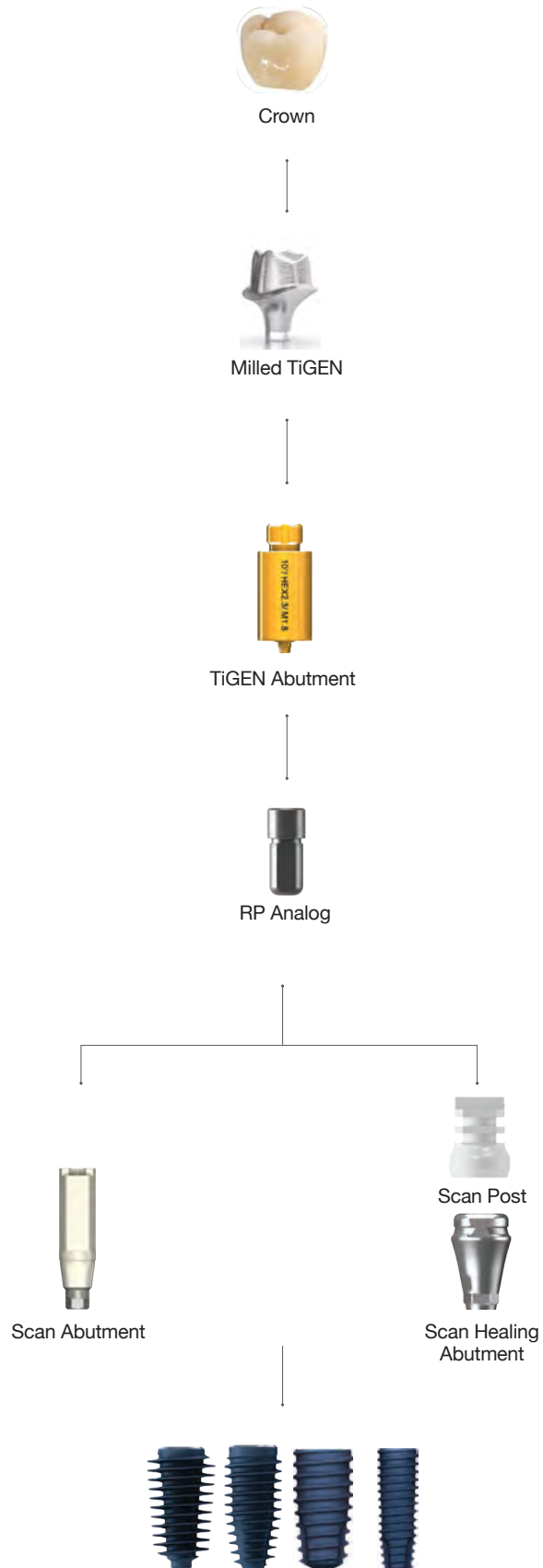

➔ TiGEN Abutment Option

TiGEN Abutment

- Abutment Screw included.
- . AnyRidge (AANMSF)
- . MiNi (MIAZ1410)
- . Octa Level(IRCS200)

- Pre-milled Abutment
- 1Set(=Abutment 10ea)
- included spare Abutment Screw
- Supporting DentalCAD
- 3Shape
- Exocad
- Dental Wings

Standard

System	Color	Diameter	Length	Type	Ref.C	
AnyRidge	Gold	Ø10	20	Hex	ARTR1020.MTN	
				Non-Hex	ARTR1020N.MTN	
		Ø12		Hex	ARTR1220.MTN	
				Non-Hex	ARTR1220N.MTN	
Octa Level	Small	N/A	20	Octa	OCTS1020.MTN	
				Non-Octa	NOTS1020.MTN	
				Octa	OCTS1220.MTN	
				Non-Octa	NOTS1220.MTN	
				Octa	OCTR1020.MTN	
				Non-Octa	NOTR1020.MTN	
	Regular	N/A			Octa	OCTR1220.MTN
					Non-Octa	NOTR1220.MTN
					Octa	OCTW1020.MTN
					Non-Octa	NOTW1020.MTN
					Octa	OCTW1220.MTN
					Non-Octa	NOTW1220.MTN
Wide		Ø10		Octa	OCTW1020.MTN	
				Non-Octa	NOTW1020.MTN	
		Ø12		Octa	OCTW1220.MTN	
				Non-Octa	NOTW1220.MTN	



Extra EZ Connection

System	Color	Fixture Core	Diameter	Length	Type	Ref.C	
AnyRidge	Gold	3.3	Ø10	20	Hex	ARTXN1020.MTN	
					Non-Hex	ARTXN1020N.MTN	
					Hex	ARTXN1220.MTN	
					Non-Hex	ARTXN1220N.MTN	
					Hex	ARTXM1020.MTN	
					Non-Hex	ARTXM1020N.MTN	
		4.0	Ø10			Hex	ARTXM1220.MTN
						Non-Hex	ARTXM1220N.MTN
						Hex	ARTXL1020.MTN
						Non-Hex	ARTXL1020N.MTN
						Hex	ARTXL1220.MTN
						Non-Hex	ARTXL1220N.MTN
4.8	Ø10			Hex	ARTXL1020.MTN		
				Non-Hex	ARTXL1020N.MTN		
	Ø12			Hex	ARTXL1220.MTN		
				Non-Hex	ARTXL1220N.MTN		





MegaGen Implant Co., Ltd.

www.megagenamerica.com

USA Office 600 Sylvan Ave Suite 404, Englewood Cliffs, NJ 07632

T. +1-844-288-5425

Head Office & Factory 45, Secheon-ro 7-gil, Dasa-eup, Dalseong-gun, Daegu, Korea

T. +82-1544-2285

Gangnam Office MegaGen Tower, 607, Seolleung-ro, Gangnam-gu, Seoul, Korea

T. +82-1566-2338



MegaGen Implant Co., Ltd. 2022.v1. All rights reserved.

ANYRIDGE[®]
by MEGA'GEN

The Biologically Driven Implant
Designed to Optimize Hard & Soft Tissues



600 Sylvan Ave, Suite 404, Englewood Cliffs, NJ 07632, USA

T. (844) 288-5425

www.megagenamerica.com